

NEW!

MLCA形 (円筒形メタライズドポリプロピレンフィルムコンデンサ)

特長

- 高耐圧、高リップル電流対応の大型直流用フィルムコンデンサです。
- 大型のインバータや電源など高電圧・高リップル電流が必要な用途に適しています。

■製品仕様

項目	仕様
使用温度範囲	-40 ~ +85°C
定格電圧 U_N	600 ~ 2,200Vdc
試験電圧 (端子間) U_{TT}	$1.5 \times U_N / 10s$
試験電圧 (T-C間) U_{Tc}	$\geq 3,000Vac / 10s$
端子 (締付トルク)	M6×10 (Max. 5Nm)
スタッドボルト (締付トルク)	M12×16 (Max. 12Nm)
関連規格	IEC 61071:2017
誘電体	ポリプロピレン
ケース	アルミニウム
環境対応	RoHS対応品

■各部寸法 [mm]

ϕD	L_1	形状記号	P	ϕd_T	L_2	L_C
$\phi 76$	—	B	32	$\phi 12$	$L_1 + 5$	32
$\phi 86$	—	B	32	$\phi 12$	$L_1 + 5$	32
$\phi 116$	< 100	H	50	$\phi 14$	$L_1 + 5$	10
$\phi 116$	100 <	I	50	$\phi 14$	$L_1 + 5$	45

■形状および外形寸法

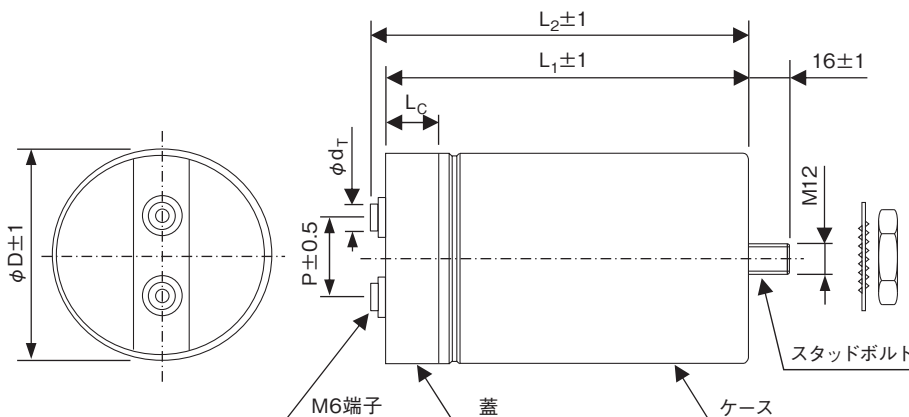

■製品記号

例: MLCA, 1,100V.dc, 2,000 μ F, $\pm 10\%$, D= $\phi 116$, $L_1 = 345$, スタッドボルト有り

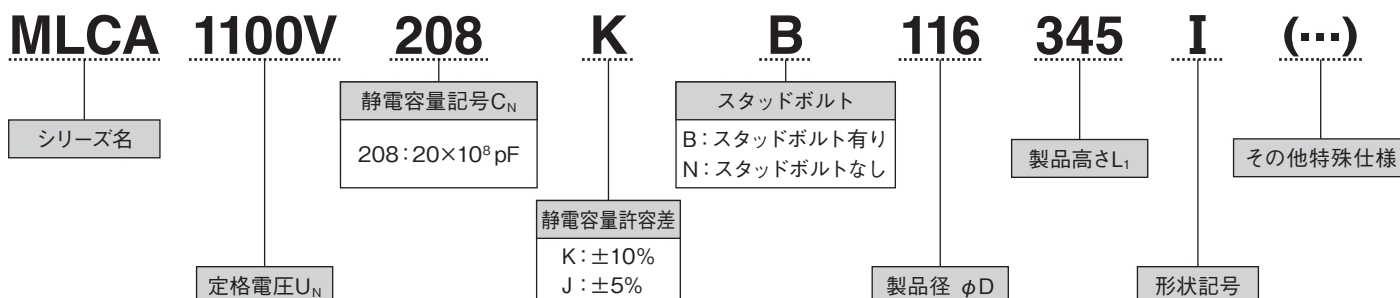

PLASTIC FILM CAPACITORS

標準品定格表

公称 静電容量 C_N 〔 μF 〕	寸法		許容リップル電流 〔Arms〕, 1kHz I_{max}^*			等価直列抵抗 (代表値) ESR 〔m Ω 〕	内部インダクタンス (代表値) ESL 〔nH〕	熱抵抗 (代表値) R_{th} 〔K/W〕	製品記号 (公差±10%、 スタッドボルトありの場合)
	径 ϕD 〔mm〕	ケース高さ L_1 〔mm〕	40℃	50℃	60℃				
定格電圧 U_N : 600Vdc	試験電圧 (T-T間) U_{TT} : 900Vdc/10s 試験電圧 (T-C間) U_{TC} : 3,000Vac/10s								
480	76	95	70	61	50	1.6	50	5.1	MLCA600V487KB7695B
650	86	95	81	70	57	1.1	50	5.6	MLCA600V657KB8695B
650	76	120	67	58	47	1.9	60	4.7	MLCA600V657KB76120B
770	76	136	88	76	62	1.2	60	4.3	MLCA600V777KB76136B
880	86	120	80	69	57	1.3	60	4.8	MLCA600V887KB86120B
950	76	175	82	71	58	1.4	60	4.2	MLCA600V957KB76175B
1,000	86	136	93	81	66	1.0	60	4.6	MLCA600V108KB86136B
1,100	86	155	81	70	57	1.4	50	4.4	MLCA600V118KB86155B
1,200	116	95	96	83	68	0.8	50	5.4	MLCA600V128KB11695H
1,300	86	175	96	84	68	1.0	60	4.3	MLCA600V138KB86175B
1,600	116	120	94	82	67	0.9	60	5.0	MLCA600V168KB116120I
1,800	86	225	95	83	67	1.1	60	4.0	MLCA600V188KB86225B
1,900	116	136	86	75	61	1.1	60	4.9	MLCA600V198KB116136I
2,100	116	155	100	100	85	0.6	60	4.6	MLCA600V218KB116155I
2,400	116	175	100	100	86	0.6	60	4.5	MLCA600V248KB116175I
3,000	116	230	100	100	96	0.8	60	2.7	MLCA600V308KB116230I
5,000	116	345	100	100	100	0.9	80	2.2	MLCA600V508KB116345I
定格電圧 U_N : 700Vdc	試験電圧 (T-T間) U_{TT} : 1,050Vdc/10s 試験電圧 (T-C間) U_{TC} : 3,000Vac/10s								
350	76	95	70	61	50	1.6	60	5.1	MLCA700V357KB7695B
480	76	120	64	55	45	2.1	60	4.7	MLCA700V487KB76120B
480	86	95	71	62	51	1.4	60	5.6	MLCA700V487KB8695B
580	76	136	60	52	43	2.4	60	4.6	MLCA700V587KB76136B
620	76	155	79	68	56	1.5	60	4.3	MLCA700V627KB76155B
700	76	175	77	67	55	1.6	60	4.2	MLCA700V707KB76175B
750	86	136	66	57	47	2.0	60	4.6	MLCA700V757KB86136B
780	86	136	68	59	48	1.9	60	4.6	MLCA700V787KB86136B
920	116	95	100	89	73	0.7	60	5.4	MLCA700V927KB11695H
950	86	175	79	68	56	1.5	60	4.3	MLCA700V957KB86175B
1,200	116	120	89	77	63	1.0	60	5.0	MLCA700V128KB116120I
1,500	116	136	86	75	61	1.1	60	4.9	MLCA700V158KB116136I
1,500	116	155	100	90	74	0.8	60	4.6	MLCA700V158KB116155I
1,800	116	175	94	82	67	1.0	60	4.5	MLCA700V188KB116175I
2,300	116	230	100	100	96	0.8	60	2.7	MLCA700V238KB116230I
定格電圧 U_N : 800Vdc	試験電圧 (T-T間) U_{TT} : 1,200Vdc/10s 試験電圧 (T-C間) U_{TC} : 3,000Vac/10s								
280	76	95	68	59	48	1.7	50	5.1	MLCA800V287KB7695B
370	86	95	69	60	49	1.5	50	5.6	MLCA800V377KB8695B
430	76	136	57	49	40	2.6	60	4.6	MLCA800V437KB76136B
470	76	155	76	66	54	1.6	60	4.3	MLCA800V477KB76155B
510	86	120	70	61	50	1.7	60	4.8	MLCA800V517KB86120B
560	76	175	73	63	51	1.7	60	4.2	MLCA800V567KB76175B
580	86	136	68	59	48	1.9	60	4.6	MLCA800V587KB86136B
640	86	155	91	79	64	1.1	50	4.4	MLCA800V647KB86155B
710	116	95	82	71	58	1.1	50	5.4	MLCA800V717KB11695H
750	86	175	85	73	60	1.3	60	4.3	MLCA800V757KB86175B
970	116	120	82	71	58	1.2	60	5.0	MLCA800V977KB116120I
1,000	86	225	85	73	60	1.4	60	4.0	MLCA800V108KB86225B
1,000	116	136	76	66	54	1.4	60	4.9	MLCA800V108KB116136I
1,200	116	155	100	90	74	0.8	60	4.6	MLCA800V128KB116155I
1,400	116	175	100	91	75	0.8	60	4.5	MLCA800V148KB116175I
1,800	116	230	100	100	86	1.0	60	2.7	MLCA800V188KB116230I
3,300	116	345	100	100	100	0.9	80	2.2	MLCA800V338KB116345I
定格電圧 U_N : 900Vdc	試験電圧 (T-T間) U_{TT} : 1,350Vdc/10s 試験電圧 (T-C間) U_{TC} : 3,000Vac/10s								
280	76	95	63	54	44	2.0	50	5.1	MLCA900V287KB7695B
370	86	95	67	58	47	1.6	50	5.6	MLCA900V377KB8695B
380	76	120	56	49	40	2.6	60	4.7	MLCA900V387KB76120B
430	76	136	55	47	39	2.9	60	4.6	MLCA900V437KB76136B
470	76	155	74	64	52	1.7	60	4.3	MLCA900V477KB76155B
510	86	120	68	59	48	1.8	60	4.8	MLCA900V517KB86120B
560	76	175	69	60	49	2.0	60	4.2	MLCA900V567KB76175B
580	86	136	64	56	46	2.1	60	4.6	MLCA900V587KB86136B
640	86	155	87	75	62	1.2	50	4.4	MLCA900V647KB86155B
710	116	95	79	68	56	1.2	50	5.4	MLCA900V717KB11695H
750	86	175	82	71	58	1.4	60	4.3	MLCA900V757KB86175B
970	116	120	78	68	55	1.3	60	5.0	MLCA900V977KB116120I
1,000	86	225	82	71	58	1.5	60	4.0	MLCA900V108KB86225B
1,000	116	136	74	64	52	1.5	60	4.9	MLCA900V108KB116136I
1,200	116	155	93	81	66	1.0	60	4.6	MLCA900V128KB116155I
1,400	116	175	99	86	70	0.9	60	4.5	MLCA900V148KB116175I
1,800	116	230	100	100	82	1.1	60	2.7	MLCA900V188KB116230I
3,300	116	345	100	100	95	1.0	80	2.2	MLCA900V338KB116345I

*リップル電流に低周波(商用周波数)や10kHzを超える成分が多く含まれる場合はご相談下さい。

パワーエレクトロニクス用プラスチックフィルムコンデンサ

■標準品定格表

公称 静電容量 C_N [μF]	寸法		許容リップル電流 [Arms], 1kHz I_{max} *			等価直列抵抗 (代表値) ESR [m Ω]	内部インダクタンス (代表値) ESL [nH]	熱抵抗 (代表値) R_{th} [K/W]	製品記号 (公差 $\pm 10\%$ 、 スタッドボルトありの場合)
	径 ϕD [mm]	ケース高さ L_1 [mm]	40°C	50°C	60°C				
定格電圧 $U_N : 1,000Vdc$	試験電圧 (T-T間) $U_{TT} : 1,500Vdc/10s$ 試験電圧 (T-C間) $U_{TC} : 3,000Vac/10s$								
220	76	95	57	50	40	2.4	50	5.1	MLCA1000V227KB7695B
290	86	95	65	56	46	1.7	50	5.6	MLCA1000V297KB8695B
300	76	120	55	48	39	2.8	60	4.7	MLCA1000V307KB76120B
330	76	136	54	47	38	3.0	60	4.6	MLCA1000V337KB76136B
360	76	155	72	62	51	1.8	60	4.3	MLCA1000V367KB76155B
400	86	120	66	57	47	1.9	60	4.8	MLCA1000V407KB86120B
420	76	175	69	60	49	2.0	60	4.2	MLCA1000V427KB76175B
450	86	136	64	56	46	2.1	60	4.6	MLCA1000V457KB86136B
500	86	155	87	75	62	1.2	60	4.4	MLCA1000V507KB86155B
540	116	95	79	68	56	1.2	50	5.4	MLCA1000V547KB11695H
560	86	175	82	71	58	1.4	60	4.3	MLCA1000V567KB86175B
740	116	120	79	68	55	1.3	60	5.0	MLCA1000V747KB116120I
860	116	136	71	62	51	1.6	60	4.9	MLCA1000V867KB116136I
900	116	155	98	85	70	0.9	60	4.6	MLCA1000V907KB116155I
1,100	116	175	99	86	70	0.9	60	4.5	MLCA1000V118KB116175I
1,400	116	230	100	100	82	1.1	60	2.7	MLCA1000V148KB116230I
2,200	116	345	100	100	91	1.1	80	2.2	MLCA1000V228KB116345I
定格電圧 $U_N : 1,100Vdc$	試験電圧 (T-T間) $U_{TT} : 1,650Vdc/10s$ 試験電圧 (T-C間) $U_{TC} : 3,000Vac/10s$								
170	76	95	54	47	38	2.7	50	5.1	MLCA1100V177KB7695B
240	86	95	61	53	43	1.9	50	5.6	MLCA1100V247KB8695B
240	76	120	52	45	37	3.1	60	4.7	MLCA1100V247KB76120B
270	76	136	51	44	36	3.4	60	4.6	MLCA1100V277KB76136B
300	76	155	68	59	48	2.0	60	4.3	MLCA1100V307KB76155B
320	86	120	62	53	44	2.2	60	4.8	MLCA1100V327KB86120B
350	76	175	64	56	46	2.3	60	4.2	MLCA1100V357KB76175B
420	86	136	60	52	43	2.4	60	4.6	MLCA1100V427KB86136B
420	86	155	81	70	57	1.4	50	4.4	MLCA1100V427KB86155B
450	116	95	75	65	53	1.3	50	5.4	MLCA1100V457KB11695H
480	86	175	76	66	54	1.6	60	4.3	MLCA1100V487KB86175B
620	116	120	73	63	52	1.5	60	5.0	MLCA1100V627KB116120I
650	86	225	75	65	53	1.8	60	4.0	MLCA1100V657KB86225B
690	116	136	69	60	49	1.7	60	4.9	MLCA1100V697KB116136I
770	116	155	93	81	66	1.0	60	4.6	MLCA1100V777KB116155I
910	116	175	94	82	67	1.0	60	4.5	MLCA1100V917KB116175I
1,200	116	230	100	96	79	1.2	60	2.7	MLCA1100V128KB116230I
2,000	116	345	100	100	84	1.3	80	2.2	MLCA1100V208KB116345I
定格電圧 $U_N : 1,200Vdc$	試験電圧 (T-T間) $U_{TT} : 1,800Vdc/10s$ 試験電圧 (T-C間) $U_{TC} : 3,000Vac/10s$								
140	76	95	51	44	36	3.0	50	5.1	MLCA1200V147KB7695B
190	86	95	58	51	41	2.1	50	5.6	MLCA1200V197KB8695B
200	76	120	50	43	35	3.4	50	4.7	MLCA1200V207KB76120B
220	76	136	48	42	34	3.7	60	4.6	MLCA1200V227KB76136B
240	76	155	65	56	46	2.2	60	4.3	MLCA1200V247KB76155B
260	86	120	59	51	42	2.4	60	4.8	MLCA1200V267KB86120B
280	76	175	62	53	44	2.5	60	4.2	MLCA1200V287KB76175B
300	86	136	58	50	41	2.6	60	4.6	MLCA1200V307KB86136B
330	86	155	78	67	55	1.5	50	4.4	MLCA1200V337KB86155B
360	116	95	73	63	51	1.4	50	5.4	MLCA1200V367KB11695H
380	86	175	72	62	51	1.8	60	4.3	MLCA1200V387KB86175B
500	116	120	69	59	49	1.7	60	5.0	MLCA1200V507KB116120I
540	86	225	71	61	50	2.0	60	4.0	MLCA1200V547KB86225B
570	116	136	66	57	46	1.9	60	4.9	MLCA1200V577KB116136I
620	116	155	89	77	63	1.1	60	4.6	MLCA1200V627KB116155I
720	116	175	90	78	64	1.1	60	4.5	MLCA1200V727KB116175I
950	116	230	100	92	75	1.3	60	2.7	MLCA1200V957KB116230I
1,600	116	345	100	100	95	1.0	80	2.2	MLCA1200V168KB116345I

*リップル電流に低周波 (商用周波数) や10kHzを超える成分が多く含まれる場合はご相談下さい。

PLASTIC FILM CAPACITORS

■標準品定格表

公称 静電容量 C_N 〔 μF 〕	寸法		許容リップル電流 〔Arms〕, 1kHz I_{max}^*			等価直列抵抗 (代表値) ESR 〔m Ω 〕	内部インダクタンス (代表値) ESL 〔nH〕	熱抵抗 (代表値) R_{th} 〔K/W〕	製品記号 (公差±10%、 スタッドボルトありの場合)
	径 ϕD 〔mm〕	ケース高さ L_1 〔mm〕							
			40℃	50℃	60℃				
定格電圧 $U_N : 1,300Vdc$	試験電圧 (T-T間) $U_{TT} : 1,950Vdc/10s$ 試験電圧 (T-C間). $U_{TC} : 3,000Vac/10s$								
120	76	95	49	42	34	3.3	50	5.1	MLCA1300V127KB7695B
160	86	95	56	48	39	2.3	50	5.6	MLCA1300V167KB8695B
160	76	120	48	42	34	3.7	60	4.7	MLCA1300V167KB76120B
180	76	136	46	40	33	4.1	60	4.6	MLCA1300V187KB76136B
210	76	155	62	54	44	2.4	60	4.3	MLCA1300V217KB76155B
220	86	120	57	49	40	2.6	60	4.8	MLCA1300V227KB86120B
240	76	175	58	51	41	2.8	60	4.2	MLCA1300V247KB76175B
250	86	136	55	47	39	2.9	60	4.6	MLCA1300V257KB86136B
280	86	155	73	63	52	1.7	50	4.4	MLCA1300V287KB86155B
310	116	95	68	59	48	1.6	50	5.4	MLCA1300V317KB11695H
320	86	175	70	61	49	1.9	60	4.3	MLCA1300V327KB86175B
420	116	120	67	58	47	1.8	60	5.0	MLCA1300V427KB116120I
450	86	225	67	58	48	2.2	60	4.0	MLCA1300V457KB86225B
480	116	136	62	54	44	2.1	60	4.9	MLCA1300V487KB116136I
530	116	155	89	77	63	1.1	60	4.6	MLCA1300V537KB116155I
630	116	175	90	78	64	1.1	60	4.5	MLCA1300V637KB116175I
820	116	230	99	86	70	1.5	60	2.7	MLCA1300V827KB116230I
1,400	116	345	100	100	87	1.2	80	2.2	MLCA1300V148KB116345I
定格電圧 $U_N : 1,500Vdc$	試験電圧 (T-T間) $U_{TT} : 2,250Vdc/10s$ 試験電圧 (T-C間). $U_{TC} : 3,000Vac/10s$								
170	86	120	52	45	37	3.1	60	4.8	MLCA1500V177KB86120B
210	86	155	67	58	48	2.0	60	4.4	MLCA1500V217KB86155B
310	116	120	62	53	44	2.1	60	5.0	MLCA1500V317KB116120I
330	86	225	63	55	45	2.5	60	4.0	MLCA1500V337KB86225B
400	116	155	79	68	56	1.4	60	4.6	MLCA1500V407KB116155I
600	116	230	93	81	66	1.7	60	2.7	MLCA1500V607KB116230I
1,000	116	345	100	100	95	1.0	80	2.2	MLCA1500V108KB116345I
定格電圧 $U_N : 1,700Vdc$	試験電圧 (T-T間) $U_{TT} : 2,550Vdc/10s$ 試験電圧 (T-C間). $U_{TC} : 4,000Vac/10s$								
130	86	120	49	42	35	3.5	60	4.8	MLCA1700V137KB86120B
160	86	155	63	54	44	2.3	60	4.4	MLCA1700V167KB86155B
240	116	120	58	50	41	2.4	60	5.0	MLCA1700V247KB116120I
250	86	225	59	51	42	2.9	60	4.0	MLCA1700V257KB86225B
300	116	155	74	64	52	1.6	60	4.6	MLCA1700V307KB116155I
460	116	230	91	79	64	1.8	60	2.7	MLCA1700V467KB116230I
定格電圧 $U_N : 2,000Vdc$	試験電圧 (T-T間) $U_{TT} : 3,000Vdc/10s$ 試験電圧 (T-C間). $U_{TC} : 4,000Vac/10s$								
100	86	120	46	40	32	4.0	60	4.8	MLCA2000V107KB86120B
120	86	155	60	52	43	2.5	60	4.4	MLCA2000V127KB86155B
190	116	120	54	47	38	2.7	60	5.0	MLCA2000V197KB116120I
190	86	225	55	48	39	3.3	60	4.0	MLCA2000V197KB86225B
240	116	155	70	60	49	1.8	60	4.6	MLCA2000V247KB116155I
370	116	230	82	71	58	2.2	60	2.7	MLCA2000V377KB116230I
600	116	345	100	100	87	1.2	80	2.2	MLCA2000V607KB116345I
定格電圧 $U_N : 2,200Vdc$	試験電圧 (T-T間) $U_{TT} : 3,300Vdc/10s$ 試験電圧 (T-C間). $U_{TC} : 4,000Vac/10s$								
90	86	136	48	42	34	3.7	60	4.6	MLCA2200V906KB86136B
140	116	120	60	52	43	2.2	60	5.0	MLCA2200V147KB116120I
150	86	225	73	63	51	1.9	60	4.0	MLCA2200V157KB86225B
170	116	155	59	51	42	2.5	60	4.6	MLCA2200V177KB116155I
210	116	175	90	78	64	1.1	60	4.5	MLCA2200V217KB116175I
290	116	230	100	89	73	1.4	60	2.7	MLCA2200V297KB116230I
450	116	345	100	100	87	1.2	80	2.2	MLCA2200V457KB116345I

*リップル電流に低周波(商用周波数)や10kHzを超える成分が多く含まれる場合はご相談下さい。