

SCREW TERMINAL TYPE ALUMINUM ELECTROLYTIC CAPACITORS

UPGRADE!

VGR Series Useful of 4,000 hours at 105°C

• Conform RoHS

Features

• The permissible ripple current is improved to VG series by approx.60% using low ESR material.

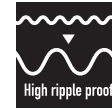
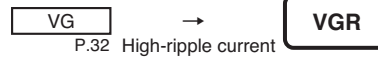

Product Specifications

Items	Specifications
Temperature range	-40°C ~ +105°C
Rated voltage	350 ~ 500V.DC
Capacitance tolerance	±20% (20°C, 120Hz)
Leakage current	0.01CV (µA) or 5mA, whichever is smaller or less (20°C, after 5 minutes) [C = nominal capacitance (µF), V = rated voltage (V)]
Dissipation factor	Less than the value specified in the standard products table. (20°C, 120Hz)
Permissible ripple current	As specified in the standard product table. (105°C, 120Hz)
Endurance	After the rated voltage with specified ripple current is applied at 105°C for 2,000 hours : Capacitance change : Within ±15% of the initial value measured Dissipation factor : 175% or less than the initial value specified Leakage current : Less than or equal to the initial value specified
Shelf life	The following specification shall be meet when the capacitor are restored to 20°C after storage of 500 hours at 105°C with no voltage applied. Before the measurement, the capacitor shall be preconditioned by applying the voltage treatment according to Item 4.1 of JIS C 5101-4. Capacitance change : Within ±15% of the initial value measured Dissipation factor : 175% or less than the initial value specified Leakage current : Less than or equal to the initial value specified
Others	JIS C 5101-4

Dimensions

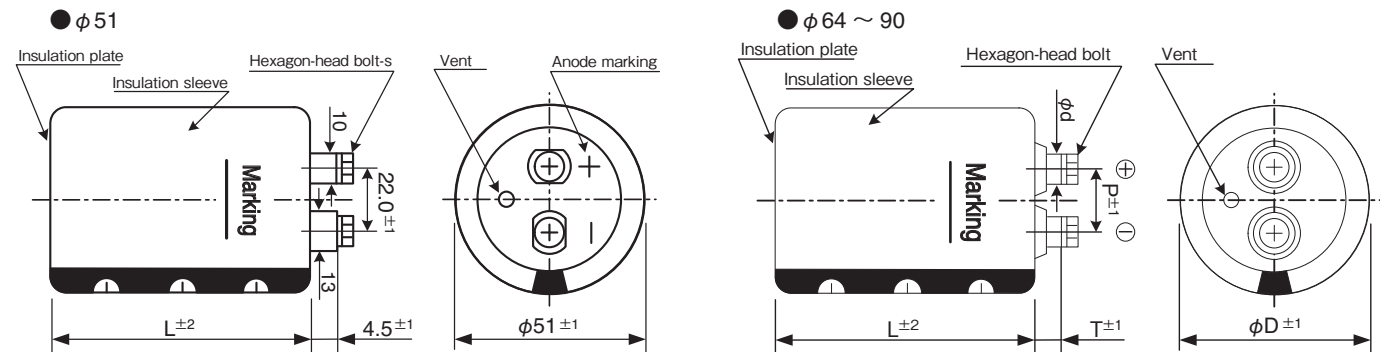

Ripple current correction coefficient

Temperature (°C)	40	60	85	105	
Correction coefficient	350 ~ 450V.DC	2.10	1.90	1.55	1.00
	500V.DC	2.10	2.00	1.87	1.00
Frequency (Hz)	120	300	1k	≥10k	
	Correction coefficient	1.0	1.1	1.3	1.4
Forced wind (m/s)	<0.5	0.5 ≤			
Correction coefficient	1.0	1.1			

(unit : mm)

φ D	P	T	φ d	Hexagon-head bolt	Cap material
51	22.0	4.5	—	M5 × 10	Phenol resin
64	28.6	8.0	11.0	M5 × 10	Phenol resin
77	31.5	9.0	12.0	M6 × 12	Phenol resin
90	31.5	8.0	12.0	M6 × 12	Phenol resin

Terminal permissible current is limited to 60Arms for M5, 100Arms for M6. (Even if calculated the permissible ripple current with the correction coefficient exceeds 60Arms for M5, 100Arms for M6) Please consult us when the ripple voltage exceeds 50 Vp-p.

Refer to page 21 for product code.

Bracket

- Refer to page 22-23 for shapes and dimensions.
- Product names in the Standard Products Table correspond to the bracket for Type Y, but Type I bracket may be used (Type of bracket code = I).
- If bracket are not necessary, enter "N" for the type of bracket code.
- Bracket will be delivered separately.

Product code

(Example) VGR type 400V 5,600 µF ±20%

VGR 2G 562 Y F 110

- VGR: Type of series
- 2G: Case height code
- 562: Capacitance code
- Y: Type of bracket code
- F: Rated voltage code
- 110: Case dia code

ALUMINUM ELECTROLYTIC CAPACITORS

SCREW TERMINAL TYPE ALUMINUM ELECTROLYTIC CAPACITORS

VGR Series

Standard Products Table

Rated Voltage (V. DC)	Capacitance (μF)	Case size φD×L(mm)	tanδ 20°C, 120Hz	Ripple current (Arms) 105°C, 120Hz	ESR(typ.) (mΩ) 20°C, 100Hz	Z max (mΩ) 20°C, 10kHz	ESL(typ.) (nH)	Product name
350	1,800	51×96	0.20	9.1	54	55	21	VGR2V182YC096
	2,200	51×109	0.20	10.2	44	45	21	VGR2V222YC109
	2,700	51×125	0.20	11.4	36	37	21	VGR2V272YC125
	3,300	64×107	0.20	15.1	29	30	22	VGR2V332YD107
	3,900	64×123	0.20	16.8	24	26	22	VGR2V392YD123
	4,700	64×147	0.20	18.2	20	21	22	VGR2V472YD147
		77×108	0.20	20.6	20	21	24	VGR2V472YE108
	5,600	64×164	0.20	20.3	17	18	22	VGR2V562YD164
		77×124	0.20	23.1	17	18	24	VGR2V562YE124
	6,800	64×187	0.20	22.6	14	15	22	VGR2V682YD187
		77×148	0.20	24.9	14	15	24	VGR2V682YE148
		90×110	0.20	28.6	14	15	24	VGR2V682YF110
	8,200	77×165	0.20	27.9	12	12	24	VGR2V822YE165
		90×150	0.20	31.0	12	12	24	VGR2V822YF150
	10,000	77×188	0.20	31.0	9	10	24	VGR2V103YE188
		90×150	0.20	34.2	9	10	24	VGR2V103YF150
12,000	77×228	0.20	35.1	8	8	24	VGR2V123YE228	
	90×167	0.20	36.8	8	8	24	VGR2V123YF167	
15,000	90×190	0.20	41.5	6	7	24	VGR2V153YF190	
18,000	90×230	0.20	44.3	5	6	24	VGR2V183YF230	
22,000	90×268	0.20	45.0	4	5	24	VGR2V223YF268	
400	1,500	51×96	0.20	8.4	63	67	21	VGR2G152YC096
	1,800	51×109	0.20	9.4	53	56	21	VGR2G182YC109
	2,200	51×125	0.20	10.6	43	46	21	VGR2G222YC125
	2,700	64×107	0.20	13.6	35	37	22	VGR2G272YD107
	3,300	64×123	0.20	15.5	29	30	22	VGR2G332YD123
	3,900	64×147	0.20	16.5	24	26	22	VGR2G392YD147
		77×108	0.20	18.8	24	26	24	VGR2G392YE108
	4,700	64×164	0.20	18.6	20	21	22	VGR2G472YD164
		77×124	0.20	21.2	20	21	24	VGR2G472YE124
	5,600	64×187	0.20	20.5	17	18	22	VGR2G562YD187
		77×148	0.20	22.6	17	18	24	VGR2G562YE148
		90×110	0.20	26.0	17	18	24	VGR2G562YF110
	6,800	77×165	0.20	25.4	14	15	24	VGR2G682YE165
		90×150	0.20	28.2	14	15	24	VGR2G682YF150
	8,200	77×188	0.20	28.1	12	12	24	VGR2G822YE188
		90×150	0.20	31.0	12	12	24	VGR2G822YF150
10,000	77×228	0.20	32.0	9	10	24	VGR2G103YE228	
	90×167	0.20	33.6	9	10	24	VGR2G103YF167	
12,000	90×190	0.20	37.1	8	8	24	VGR2G123YF190	
15,000	90×230	0.20	40.4	6	7	24	VGR2G153YF230	
18,000	90×268	0.20	40.6	5	6	24	VGR2G183YF268	
450	1,200	51×96	0.20	7.9	79	83	21	VGR2W122YC096
	1,500	51×109	0.20	9.0	64	66	21	VGR2W152YC109
	1,800	51×125	0.20	10.1	53	55	21	VGR2W182YC125
	2,200	64×107	0.20	12.6	43	45	22	VGR2W222YD107
	2,700	64×123	0.20	14.4	35	37	22	VGR2W272YD123
		77×108	0.20	16.1	35	37	24	VGR2W272YE108
	3,300	64×147	0.20	15.6	29	30	22	VGR2W332YD147
		77×124	0.20	18.2	29	30	24	VGR2W332YE124
	3,900	64×164	0.20	17.5	24	26	22	VGR2W392YD164
		77×148	0.20	19.4	24	26	24	VGR2W392YE148
		90×110	0.20	22.3	24	26	24	VGR2W392YF110
	4,700	64×187	0.20	19.3	20	21	22	VGR2W472YD187
		77×148	0.20	21.3	20	21	24	VGR2W472YE148
		90×126	0.20	24.2	20	21	24	VGR2W472YF126
	5,600	77×165	0.20	23.7	17	18	24	VGR2W562YE165
		90×150	0.20	26.3	17	18	24	VGR2W562YF150
6,800	77×188	0.20	26.3	14	15	24	VGR2W682YE188	
	90×167	0.20	28.5	14	15	24	VGR2W682YF167	
8,200	77×228	0.20	29.8	12	12	24	VGR2W822YE228	
	90×190	0.20	31.5	12	12	24	VGR2W822YF190	
10,000	90×230	0.20	33.9	9	10	24	VGR2W103YF230	
15,000	90×268	0.20	38.2	6	7	24	VGR2W153YF268	

ALUMINUM ELECTROLYTIC CAPACITORS

SCREW TERMINAL TYPE ALUMINUM ELECTROLYTIC CAPACITORS

Standard Products Table

Rated Voltage (V. DC)	Capacitance (μ F)	Case size ϕ D \times L(mm)	$\tan\delta$ 20°C, 120Hz	Ripple current (Arms) 105°C, 120Hz	ESR(typ.) (m Ω) 20°C, 100Hz	Z max (m Ω) 20°C, 10kHz	ESL(typ.) (nH)	Product name
500	680	51 \times 96	0.20	4.6	153	162	21	VGR2H681YC096
	820	51 \times 109	0.20	5.2	127	134	21	VGR2H821YC109
	1,000	51 \times 125	0.20	5.9	104	110	21	VGR2H102YC125
	1,500	64 \times 107	0.20	8.4	69	73	22	VGR2H152YD107
	1,800	64 \times 123	0.20	9.5	58	61	22	VGR2H182YD123
	2,200	64 \times 147	0.20	10.3	47	50	22	VGR2H222YD147
		77 \times 108	0.20	11.7	47	50	24	VGR2H222YE108
	2,700	64 \times 187	0.20	11.8	39	41	22	VGR2H272YD187
		77 \times 124	0.20	13.3	39	41	24	VGR2H272YE124
	3,300	77 \times 148	0.20	14.4	32	33	24	VGR2H332YE148
		90 \times 110	0.20	16.5	32	33	24	VGR2H332YF110
	3,900	77 \times 165	0.20	15.9	27	28	24	VGR2H392YE165
		90 \times 126	0.20	17.8	27	28	24	VGR2H392YF126
	4,700	77 \times 188	0.20	17.6	22	23	24	VGR2H472YE188
		90 \times 150	0.20	19.4	22	23	24	VGR2H472YF150
	5,600	77 \times 228	0.20	19.8	19	20	24	VGR2H562YE228
		90 \times 167	0.20	20.8	19	20	24	VGR2H562YF167
	6,800	90 \times 190	0.20	23.1	15	16	24	VGR2H682YF190
8,200	90 \times 230	0.20	24.7	13	13	24	VGR2H822YF230	
10,000	90 \times 268	0.20	25.1	11	11	24	VGR2H103YF268	

ALUMINUM ELECTROLYTIC CAPACITORS

Life time graph

Useful life depending on ambient temperature T_a and ripple current operating condition I versus rated ripple current at 105°C, 120Hz

