

SCREW TERMINAL TYPE ALUMINUM ELECTROLYTIC CAPACITORS

UPGRADE!

VFLR Series Useful of 8,000 hours at 85°C

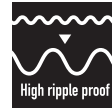

• Conform RoHS

Features

- The permissible ripple current is improved to FXR type by approx.10 ~ 20% using the new heat radiation, low ESR and the new anode foil.

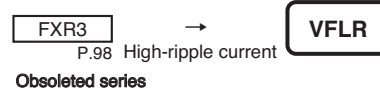

Product Specifications

Items	Specifications
Temperature range	-40°C ~ +85°C
Rated voltage	350 ~ 500V.DC
Capacitance tolerance	±20% (20°C, 120Hz)
Leakage current	0.01CV (μA) or 5mA, whichever is smaller or less (20°C, after 5 minutes) [C = nominal capacitance (μF), V = rated voltage (V)]
Dissipation factor	Less than the value specified in the standard products table. (20°C, 120Hz)
Permissible ripple current	As specified in the standard product table. (85°C, 120Hz)
Endurance	After the rated voltage with specified ripple current is applied at 85°C for 5,000 hours : Capacitance change : Within ±15% of the initial value measured Dissipation factor : 175% or less than the initial value specified Leakage current : Less than or equal to the initial value specified
Shelf life	The following specification shall be meet when the capacitor are restored to 20°C after storage of 500 hours at 85°C with no voltage applied. Before the measurement, the capacitor shall be preconditioned by applying the voltage treatment according to Item 4.1 of JIS C 5101-4. Capacitance change : Within ±15% of the initial value measured Dissipation factor : 175% or less than the initial value specified Leakage current : Less than or equal to the initial value specified
Others	JIS C 5101-4

Dimensions

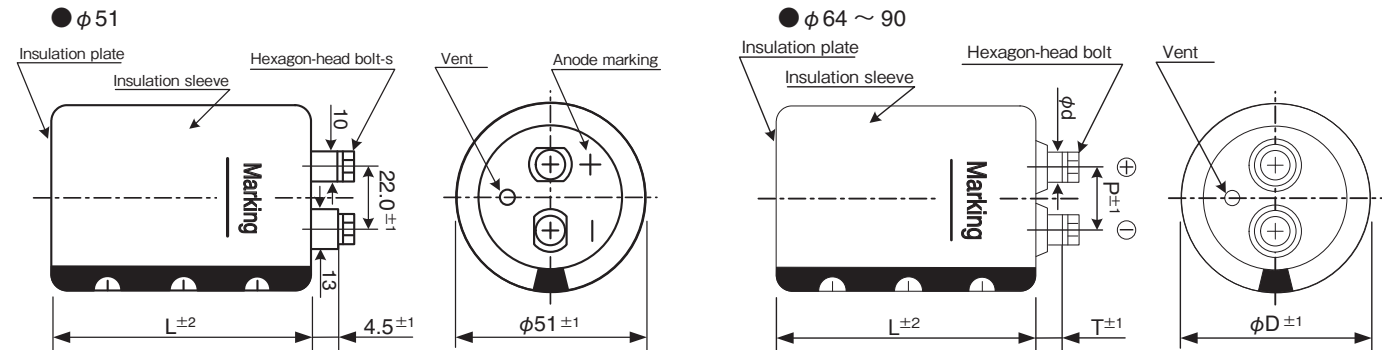

Ripple current correction coefficient

Temperature (°C)	40	60	85	
Correction coefficient	1.89	1.67	1.00	
Frequency (Hz)	120	300	1k	≥10k
Correction coefficient	1.0	1.1	1.3	1.4
Forced wind (m/s)	<0.5	0.5 ≤		
Correction coefficient	1.0	1.1		

(unit : mm)

φD	P	T	φd	Hexagon-head bolt	Cap material
51	22.0	4.5	—	M5×10	Phenol resin
64	28.6	8.0	11.0	M5×10	Phenol resin
77	31.5	9.0	12.0	M6×12	Phenol resin
90	31.5	8.0	12.0	M6×12	Phenol resin

Terminal permissible current is limited to 60Arms for M5, 100Arms for M6. (Even if calculated the permissible ripple current with the correction coefficient exceeds 60Arms for M5, 100Arms for M6) Please consult us when the ripple voltage exceeds 50 Vp-p.

Product code

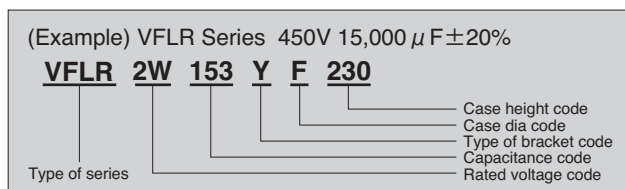

Refer to page 21 for product code.

Bracket

- Refer to page 22-23 for shapes and dimensions.
- Product names in the Standard Products Table correspond to the bracket for Type Y, but Type I bracket may be used (Type of bracket code = I).
- If bracket are not necessary, enter "N" for the type of bracket code.
- Bracket will be delivered separately.

SCREW TERMINAL TYPE ALUMINUM ELECTROLYTIC CAPACITORS

VFLR Series

Standard Products Table

Rated Voltage (V. DC)	Capacitance (μF)	Case size φD×L(mm)	tanδ 20°C, 120Hz	Ripple current (Arms) 85°C, 120Hz	ESR(typ.) (mΩ) 20°C, 100Hz	Z max (mΩ) 20°C, 10kHz	ESL(typ.) (nH)	Product name
350	2,200	51×96	0.20	10.2	43	47	21	VFLR2V222YC096
	2,700	51×109	0.20	11.4	35	38	21	VFLR2V272YC109
	3,300	51×125	0.20	12.7	29	31	21	VFLR2V332YC125
	3,900	64×107	0.20	17.0	24	26	22	VFLR2V392YD107
	4,700	64×123	0.20	19.2	20	21	22	VFLR2V472YD123
	5,600	64×147	0.20	20.6	17	18	22	VFLR2V562YD147
		77×108	0.20	23.5	17	18	24	VFLR2V562YE108
	6,800	64×164	0.20	23.3	14	15	22	VFLR2V682YD164
		77×124	0.20	26.5	14	15	24	VFLR2V682YE124
	8,200	64×187	0.20	25.8	12	12	22	VFLR2V822YD187
		77×148	0.20	28.5	12	12	24	VFLR2V822YE148
		90×110	0.20	32.6	12	12	24	VFLR2V822YF110
	10,000	77×165	0.20	32.1	9	10	24	VFLR2V103YE165
		90×126	0.20	35.9	9	10	24	VFLR2V103YF126
	12,000	77×188	0.20	35.3	8	8	24	VFLR2V123YE188
		90×150	0.20	39.1	8	8	24	VFLR2V123YF150
	15,000	77×228	0.20	40.8	6	7	24	VFLR2V153YE228
90×167		0.20	43.3	6	7	24	VFLR2V153YF167	
18,000	90×190	0.20	47.1	5	6	24	VFLR2V183YF190	
22,000	90×230	0.20	51.2	4	5	24	VFLR2V223YF230	
27,000	90×268	0.20	51.8	3	4	24	VFLR2V273YF268	
400	1,800	51×96	0.20	9.5	54	55	21	VFLR2G182YC096
	2,200	51×109	0.20	10.6	44	45	21	VFLR2G222YC109
	2,700	51×125	0.20	11.9	36	37	21	VFLR2G272YC125
	3,300	64×107	0.20	15.7	29	30	22	VFLR2G332YD107
	3,900	64×123	0.20	17.5	24	26	22	VFLR2G392YD123
	4,700	64×147	0.20	18.9	20	21	22	VFLR2G472YD147
		77×108	0.20	21.5	20	21	24	VFLR2G472YE108
	5,600	64×164	0.20	21.2	17	18	22	VFLR2G562YD164
		77×124	0.20	24.0	17	18	24	VFLR2G562YE124
	6,800	64×187	0.20	23.5	14	15	22	VFLR2G682YD187
		77×148	0.20	26.0	14	15	24	VFLR2G682YE148
		90×110	0.20	29.7	14	15	24	VFLR2G682YF110
	8,200	77×165	0.20	29.1	12	12	24	VFLR2G822YE165
		90×126	0.20	32.5	12	12	24	VFLR2G822YF126
	10,000	77×188	0.20	32.2	9	10	24	VFLR2G103YE188
		90×150	0.20	35.7	9	10	24	VFLR2G103YF150
	12,000	77×228	0.20	36.5	8	8	24	VFLR2G123YE228
90×167		0.20	38.7	8	8	24	VFLR2G123YF167	
15,000	90×190	0.20	43.0	6	7	24	VFLR2G153YF190	
18,000	90×230	0.20	46.3	5	6	24	VFLR2G183YF230	
22,000	90×268	0.20	46.8	4	5	24	VFLR2G223YF268	
450	1,500	51×96	0.20	9.0	63	67	21	VFLR2W152YC096
	1,800	51×109	0.20	10.1	53	56	21	VFLR2W182YC109
	2,200	51×125	0.20	11.3	43	46	21	VFLR2W222YC125
	2,700	64×107	0.20	14.5	35	37	22	VFLR2W272YD107
	3,300	64×123	0.20	16.5	29	30	22	VFLR2W332YD123
	3,900	64×147	0.20	17.6	24	26	22	VFLR2W392YD147
		77×108	0.20	20.1	24	26	24	VFLR2W392YE108
	4,700	64×164	0.20	19.9	20	21	22	VFLR2W472YD164
		77×124	0.20	22.6	20	21	24	VFLR2W472YE124
	5,600	64×187	0.20	21.9	17	18	22	VFLR2W562YD187
		77×148	0.20	24.1	17	18	24	VFLR2W562YE148
		90×110	0.20	27.6	17	18	24	VFLR2W562YF110
	6,800	77×165	0.20	27.1	14	15	24	VFLR2W682YE165
		90×126	0.20	30.3	14	15	24	VFLR2W682YF126
	8,200	77×188	0.20	29.9	12	12	24	VFLR2W822YE188
		90×150	0.20	33.1	12	12	24	VFLR2W822YF150
	10,000	77×228	0.20	34.1	9	10	24	VFLR2W103YE228
90×167		0.20	36.2	9	10	24	VFLR2W103YF167	
12,000	90×190	0.20	39.4	8	8	24	VFLR2W123YF190	
15,000	90×230	0.20	43.3	6	7	24	VFLR2W153YF230	
18,000	90×268	0.20	43.4	5	6	24	VFLR2W183YF268	

ALUMINUM ELECTROLYTIC CAPACITORS

SCREW TERMINAL TYPE ALUMINUM ELECTROLYTIC CAPACITORS

Standard Products Table

Rated Voltage (V. DC)	Capacitance (μ F)	Case size ϕ D×L(mm)	$\tan\delta$ 20°C, 120Hz	Ripple current (Arms) 85°C, 120Hz	ESR(typ.) (m Ω) 20°C, 100Hz	Z max (m Ω) 20°C, 10kHz	ESL(typ.) (nH)	Product name
500	820	51×96	0.20	6.1	128	134	21	VFLR2H821YC096
	1,000	51×109	0.20	7.0	105	110	21	VFLR2H102YC109
	1,200	51×125	0.20	7.9	87	92	21	VFLR2H122YC125
	1,800	64×107	0.20	11.3	58	61	22	VFLR2H182YD107
	2,200	64×123	0.20	12.8	47	50	22	VFLR2H222YD123
	2,700	64×147	0.20	13.9	39	41	22	VFLR2H272YD147
		77×108	0.20	15.9	39	41	24	VFLR2H272YE108
	3,300	64×164	0.20	15.8	32	33	22	VFLR2H332YD164
		77×124	0.20	18.0	32	33	24	VFLR2H332YE124
	3,900	64×187	0.20	17.3	27	28	22	VFLR2H392YD187
		77×148	0.20	19.1	27	28	24	VFLR2H392YE148
		90×110	0.20	21.9	27	28	24	VFLR2H392YF110
	4,700	77×165	0.20	21.4	22	23	24	VFLR2H472YE165
		90×126	0.20	24.0	22	23	24	VFLR2H472YF126
	5,600	77×188	0.20	23.5	19	20	24	VFLR2H562YE188
		90×150	0.20	26.0	19	20	24	VFLR2H562YF150
	6,800	77×228	0.20	26.7	15	16	24	VFLR2H682YE228
90×167		0.20	28.4	15	16	24	VFLR2H682YF167	
8,200	90×190	0.20	31.0	13	13	24	VFLR2H822YF190	
10,000	90×230	0.20	33.6	10	11	24	VFLR2H103YF230	
12,000	90×268	0.20	33.6	8	9	24	VFLR2H123YF268	

ALUMINUM ELECTROLYTIC CAPACITORS

Life time graph

Useful life depending on ambient temperature T_a and ripple current operating conditions I versus rated ripple current at 85°C, 120Hz

