

MLC Series (Cylindrically-Shaped Metallized Polypropylene Film Capacitors)

Features

- Cylindrically-shaped capacitor with big capacitance for wind & solar power inverters, other inverters, chopper control and charge-discharge.
- High reliability of withstanding voltage due to using of our original segmented metallized film.
- UL 810 standard option compliant. (Series : MLCU)

Specifications

Items	Characteristics
Operating Temperature range *	-40 ~ +85°C at 0.7 U_N
	-40 ~ +80°C at 0.8 U_N
	-40 ~ +75°C at 0.9 U_N
	-40 ~ +70°C at 1.0 U_N
Rated Voltage U_N	900 ~ 1,500V.DC
Voltage test between terminals U_{TT}	$1.5 \times U_N / 10s$
Voltage test terminals to case U_{TC}	3,200Vac / 10s
Terminals (permitted Torque)	M6 × 10 (4 ±0.5Nm)
Stud Bolt (permitted Torque)	M12 × 16 / 18 (7 ±1Nm)
Reference / Standard	IEC 61071 : 2007
Dielectric	Polypropylene
Safety Function	Segmented Metal with Fuse Function
Cap	PBT UL94V-0 listed
impregnants	Epoxy / Urethane Resin UL94V-0 listed
Case material	Aluminium
Humidity	Class F : 75% annual average, 95% 30days / year

		ϕD				
		$\phi 85$	$\phi 88.5$	$\phi 100$	$\phi 116$	$\phi 140$
Dimensions (mm)	P	32	32	32	50	50
	ϕdT	$\phi 12$	$\phi 12$	$\phi 12$	$\phi 14$	$\phi 19$
	L_2	5	5	5	5	5
	L_c	15	15	15	20	20
	L_s	16	16	16	18	18
Clearance distance (mm)		20	20	20	36	31
Creepage distance (mm)		28	28	28	36	31
Terminal allowance current		60Arms	60Arms	60Arms	80Arms	100Arms

Imax Multiplier (1kHz ~ 10kHz)

		$0.7 \times U_N$	$0.8 \times U_N$	$0.9 \times U_N$	$1.0 \times U_N$
T_a Ambient Temperature	50°C	1.32	1.22	1.11	1.00
	60°C	1.11	1.00	0.86	0.70
	70°C	0.86	0.70	0.50	0.00
	75°C	0.70	0.50	0.00	
	80°C	0.50	0.00		
	85°C	0.00			

Outline of drawings and dimensions

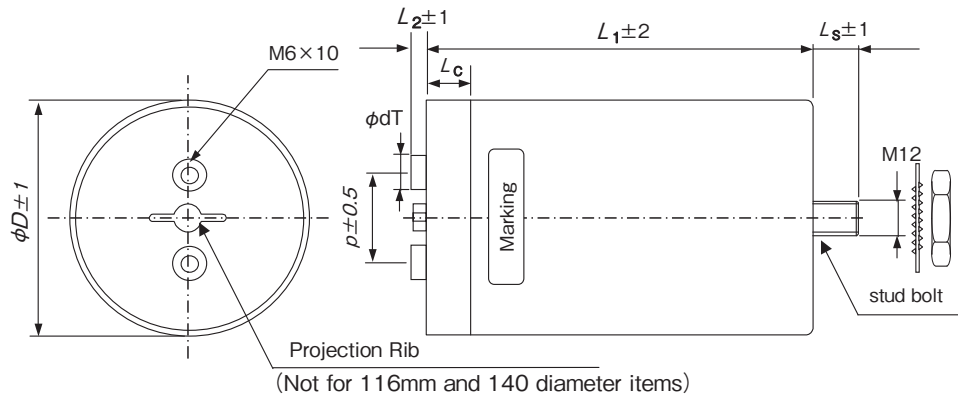

Part number

Example : MLC, 1100V, 580 μF , $\pm 10\%$, $D = \phi 116$, $L = 125$, with stud bolt
MLC1100V587KB116125

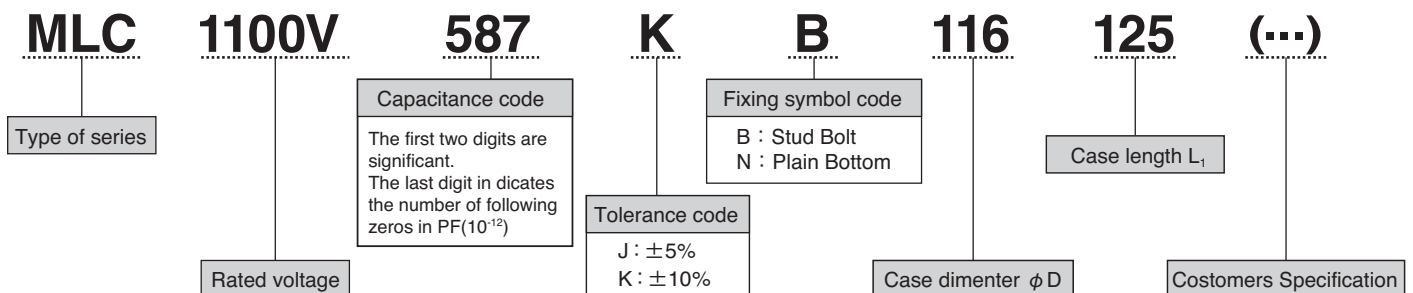

Standard Products Table

Rated d.c voltage $U_N : 900Vdc$		Max.ripple voltage $U_r : 200V$ Non repetitive surge voltage $U_s : 1,350V$ Voltage test between terminals $U_{TT} : 1,350Vdc/10s$ Voltage test terminals to case. $U_{TC} : 3,200Vac/10s$							
Nominal Capacitance C_N [μF]	Dimensions		Maximum ripple current (Arms) I_{max}^* [Arms / at50°C, 1k ~ 10kHz]	Maximum peak current \hat{i} [kA]	Maximum Surge current I_s [kA]	Equivalent Series Resistance ESR [m Ω]	Equivalent Series Inductance ESL [nH]	Thermal resistance R_{th} [K/W]	Part number
	Diameter ϕD [mm]	Length of the case L_1 [mm]							
180	85	70	28	4	12	2.9	60	8.4	MLC900V187KB8570
200	85	75	28	4	12	3.1	65	7.9	MLC900V207KB8575
210	88.5	70	31	5	15	2.6	60	7.8	MLC900V217KB88570
230	85	80	28	4	12	3.3	65	7.4	MLC900V237KB8580
	88.5	75	30	5	15	2.8	65	7.7	MLC900V237KB88575
250	88.5	80	30	4	12	3.1	65	7.0	MLC900V257KB88580
260	85	87	28	4	12	3.7	75	6.8	MLC900V267KB8587
270	100	70	37	6	18	2.2	60	6.5	MLC900V277KB10070
280	88.5	87	28	4	12	3.4	75	6.8	MLC900V287KB88587
290	85	95	27	4	12	4.1	80	6.4	MLC900V297KB8595
300	100	75	37	6	18	2.3	65	6.1	MLC900V307KB10075
320	88.5	95	29	4	12	3.8	80	6.1	MLC900V327KB88595
330	85	106	27	4	12	4.8	90	5.6	MLC900V337KB85106
	100	80	36	6	18	2.5	65	5.9	MLC900V337KB10080
360	88.5	106	28	4	12	4.4	90	5.7	MLC900V367KB885106
370	85	125	52	8	24	1.5	40	4.8	MLC900V377KB85125
	100	87	36	6	18	2.8	75	5.4	MLC900V377KB10087
380	116	70	43	8	24	1.7	60	6.0	MLC900V387KB11670
390	85	120	26	4	12	5.5	100	5.2	MLC900V397KB85120
410	85	135	52	8	24	1.6	40	4.5	MLC900V417KB85135
	116	75	43	8	24	1.9	65	5.6	MLC900V417KB11675
420	88.5	125	56	9	27	1.4	40	4.5	MLC900V427KB885125
	100	95	34	6	18	3.1	80	5.4	MLC900V427KB10095
430	88.5	120	28	5	15	5.1	100	4.9	MLC900V437KB885120
460	85	145	52	8	24	1.7	45	4.1	MLC900V467KB85145
	88.5	135	56	9	27	1.5	40	4.2	MLC900V467KB885135
	116	80	43	8	24	2.0	65	5.2	MLC900V467KB11680
480	100	106	34	6	18	3.5	90	4.7	MLC900V487KB100106
510	88.5	145	55	9	27	1.6	45	4.0	MLC900V517KB885145
520	85	159	52	8	24	1.9	50	3.8	MLC900V527KB85159
	116	87	42	8	24	2.2	75	5.0	MLC900V527KB11687
540	100	125	60	12	36	1.1	40	3.9	MLC900V547KB100125
560	100	120	33	6	18	4.1	100	4.3	MLC900V567KB100120
570	88.5	159	55	9	27	1.8	50	3.6	MLC900V577KB885159
	140	70	46	12	36	1.4	60	6.6	MLC900V577KB14070
590	85	175	52	8	24	2.1	55	3.4	MLC900V597KB85175
	116	95	42	8	24	2.4	80	4.5	MLC900V597KB11695
600	100	135	60	12	36	1.2	40	3.6	MLC900V607KB100135
630	140	75	46	12	36	1.4	65	6.6	MLC900V637KB14075
650	88.5	175	55	9	27	2.0	55	3.2	MLC900V657KB885175
	85	197	51	8	24	2.5	60	3.0	MLC900V667KB85197
660	116	106	41	8	24	2.8	90	4.2	MLC900V667KB116106
	100	145	60	12	36	1.3	45	3.5	MLC900V677KB100145
700	140	80	46	12	36	1.6	65	5.8	MLC900V707KB14080
730	88.5	197	54	9	27	2.3	60	2.9	MLC900V737KB885197
750	100	159	60	12	36	1.5	50	3.2	MLC900V757KB100159
760	116	125	77	16	48	0.9	40	3.5	MLC900V767KB116125
	85	225	50	8	24	2.9	70	2.7	MLC900V787KB85225
	116	120	41	8	24	3.2	100	3.6	MLC900V787KB116120
830	140	87	46	12	36	1.7	75	5.4	MLC900V787KB14087
	116	135	77	16	48	1.0	40	3.3	MLC900V837KB116135
850	100	175	60	12	36	1.6	55	2.8	MLC900V857KB100175
870	88.5	225	54	9	27	2.6	70	2.6	MLC900V877KB885225
890	140	95	45	12	36	1.9	80	5.1	MLC900V897KB14095
930	116	145	77	16	48	1.1	45	3.1	MLC900V937KB116145
960	100	197	60	12	36	1.9	60	2.5	MLC900V967KB100197
1,000	116	159	76	16	48	1.2	50	2.8	MLC900V108KB116159
	140	106	44	12	36	2.1	90	4.8	MLC900V108KB140106
1,100	100	225	60	11	33	2.2	70	2.2	MLC900V118KB100225
	116	175	75	15	45	1.4	55	2.5	MLC900V118KB116175
	140	120	43	11	33	2.5	100	4.2	MLC900V118KB140120
1,200	140	125	80	24	72	0.8	40	3.8	MLC900V118KB140125
	140	135	80	23	69	0.8	40	3.8	MLC900V128KB140135
1,300	116	197	75	16	48	1.5	60	2.3	MLC900V138KB116197
1,400	140	145	81	24	72	0.8	45	3.7	MLC900V148KB140145
1,500	116	225	74	16	48	1.8	70	2.0	MLC900V158KB116225
	140	159	80	23	69	0.9	50	3.4	MLC900V158KB140159
1,700	140	175	79	23	69	1.0	55	3.2	MLC900V178KB140175
2,000	140	197	80	24	72	1.2	60	2.6	MLC900V208KB140197
2,300	140	225	79	24	72	1.3	70	2.3	MLC900V238KB140225

PLASTIC FILM CAPACITORS

* • Please inquire us in case low frequency (commercial frequency) or frequency above 10kHz is included in ripple current.
 • Maximum permissible ripple current is calculated by the value in this table with frequency and temperature correction factors.
 Also the maximum current must be controlled below the permissible terminal current .
 Please refer useful life graph based on ambient temperature and voltage.

$$\theta_{HOTSPOT} = T_a + I^2 \times ESR \times R_{th}$$

POWER ELECTRONICS USE PLASTIC FILM CAPACITORS

Standard Products Table

Rated d.c voltage $U_N : 1,100Vdc$	Max.ripple voltage $U_r : 250V$ Non repetitive surge voltage $U_s : 1,650V$ Voltage test between terminals $U_{TT} : 1,650Vdc/10s$ Voltage test terminals to case. $U_{TC} : 3,200Vac/10s$								
	Nominal Capacitance C_N [μF]	Dimensions		Maximum ripple current (Arms) I_{max}^* [Arms / at50°C, 1k ~ 10kHz]	Maximum peak current \hat{i} [kA]	Maximum Surge current I_s [kA]	Equivalent Series Resistance ESR [m Ω]	Equivalent Series Inductance ESL [nH]	Thermal resistance R_{th} [K/W]
	Diameter ϕD [mm]	Length of the case L_1 [mm]							
140	85	70	26	3	9	3.3	60	8.6	MLC1100V147KB8570
160	85	75	27	4	12	3.5	65	7.6	MLC1100V167KB8575
170	88.5	70	29	4	12	2.8	60	8.3	MLC1100V177KB88570
180	85	80	27	4	12	3.7	65	7.1	MLC1100V187KB8580
	88.5	75	29	4	12	3.1	65	7.5	MLC1100V187KB88575
200	85	87	26	4	12	4.2	75	6.9	MLC1100V207KB8587
	88.5	80	28	4	12	3.4	65	7.3	MLC1100V207KB88580
210	100	70	34	5	15	2.4	60	6.9	MLC1100V217KB10070
230	85	95	26	4	12	4.6	80	6.2	MLC1100V237KB8595
	88.5	87	28	4	12	3.7	75	6.7	MLC1100V237KB88587
	100	75	34	5	15	2.6	65	6.4	MLC1100V237KB10075
260	85	106	25	4	12	5.3	90	5.8	MLC1100V267KB85106
	88.5	95	28	4	12	4.1	80	6.1	MLC1100V267KB88595
	100	80	33	5	15	2.8	65	6.3	MLC1100V267KB10080
290	85	125	50	7	21	1.7	40	4.7	MLC1100V297KB85125
	88.5	106	27	4	12	4.8	90	5.6	MLC1100V297KB885106
	100	87	33	5	15	3.1	75	5.8	MLC1100V297KB10087
	116	70	41	7	21	1.9	60	6.0	MLC1100V297KB11670
310	85	120	25	4	12	6.1	100	5.1	MLC1100V317KB85120
320	85	135	50	7	21	1.8	40	4.3	MLC1100V327KB85135
	116	75	41	7	21	2.1	65	5.6	MLC1100V327KB11675
330	88.5	125	53	8	24	1.5	40	4.6	MLC1100V337KB885125
	100	95	33	5	15	3.4	80	5.2	MLC1100V337KB10095
350	88.5	120	27	4	12	5.5	100	4.9	MLC1100V357KB885120
360	85	145	49	7	21	1.9	45	4.2	MLC1100V367KB85145
	116	80	41	7	21	2.2	65	5.2	MLC1100V367KB11680
370	88.5	135	54	8	24	1.6	40	4.2	MLC1100V377KB885135
380	100	106	32	5	15	3.9	90	4.8	MLC1100V387KB100106
400	85	159	49	7	21	2.2	50	3.7	MLC1100V407KB85159
	116	87	40	7	21	2.4	75	5.0	MLC1100V407KB11687
410	88.5	145	53	8	24	1.7	45	4.1	MLC1100V417KB885145
440	100	125	60	10	30	1.2	40	3.9	MLC1100V447KB100125
450	100	120	32	5	15	4.5	100	4.2	MLC1100V457KB100120
460	85	175	49	7	21	2.4	55	3.4	MLC1100V467KB85175
	88.5	159	53	8	24	1.9	50	3.7	MLC1100V467KB885159
	116	95	40	7	21	2.7	80	4.5	MLC1100V467KB11695
	140	70	45	11	33	1.4	60	6.9	MLC1100V467KB14070
470	100	135	60	10	30	1.4	40	3.6	MLC1100V477KB100135
500	140	75	45	11	33	1.6	65	6.0	MLC1100V507KB14075
520	100	145	60	10	30	1.5	45	3.4	MLC1100V527KB100145
530	85	197	48	7	21	2.7	60	3.1	MLC1100V537KB85197
	88.5	175	53	8	24	2.1	55	3.3	MLC1100V537KB885175
	116	106	40	7	21	3.0	90	4.0	MLC1100V537KB116106
560	140	80	44	11	33	1.7	65	5.9	MLC1100V567KB14080
	100	159	60	10	30	1.6	50	3.1	MLC1100V587KB100159
580	116	125	73	14	42	1.0	40	3.6	MLC1100V587KB116125
	88.5	197	52	8	24	2.5	60	2.9	MLC1100V597KB885197
620	85	225	48	7	21	3.2	70	2.7	MLC1100V627KB85225
	116	120	39	7	21	3.5	100	3.6	MLC1100V627KB116120
630	140	87	44	11	33	1.8	75	5.6	MLC1100V637KB14087
650	116	135	74	14	42	1.1	40	3.3	MLC1100V657KB116135
690	100	175	60	10	30	1.7	55	2.9	MLC1100V697KB100175
700	88.5	225	51	8	24	2.9	70	2.6	MLC1100V707KB885225
720	116	145	74	14	42	1.2	45	3.0	MLC1100V727KB116145
	140	95	44	11	33	2.0	80	5.0	MLC1100V727KB14095
760	100	197	60	10	30	2.0	60	2.5	MLC1100V767KB100197
810	116	159	73	14	42	1.3	50	2.8	MLC1100V817KB116159
	140	106	43	11	33	2.3	90	4.6	MLC1100V817KB140106
900	100	225	60	10	30	2.4	70	2.2	MLC1100V907KB100225
920	116	175	73	14	42	1.4	55	2.6	MLC1100V927KB116175
	140	125	79	22	66	0.8	40	3.9	MLC1100V927KB140125
950	140	120	43	11	33	2.6	100	4.1	MLC1100V957KB140120
1,000	116	197	71	14	42	1.7	60	2.3	MLC1100V108KB116197
	140	135	79	22	66	0.8	40	3.9	MLC1100V108KB140135
1,100	140	145	78	22	66	0.9	45	3.6	MLC1100V118KB140145
1,200	116	225	71	14	42	1.9	70	2.0	MLC1100V128KB116225
	140	159	77	21	63	1.0	50	3.3	MLC1100V128KB140159
1,400	140	175	78	21	63	1.1	55	2.9	MLC1100V148KB140175
1,600	140	197	77	22	66	1.2	60	2.8	MLC1100V168KB140197
1,900	140	225	77	22	66	1.4	70	2.4	MLC1100V198KB140225

* • Please inquire us in case low frequency (commercial frequency) or frequency above 10kHz is included in ripple current.
 • Maximum permissible ripple current is calculated by the value in this table with frequency and temperature correction factors.
 Also the maximum current must be controlled below the permissible terminal current .
 Please refer useful life graph based on ambient temperature and voltage.

$$\theta_{HOTSPOT} = T_a + I^2 \times ESR \times R_{th}$$

PLASTIC FILM CAPACITORS

Standard Products Table

Rated d.c voltage $U_N : 1,300Vdc$		Max.ripple voltage $U_r : 300V$ Non repetitive surge voltage $U_s : 1,950V$ Voltage test between terminals $U_{TT} : 1,950Vdc/10s$ Voltage test terminals to case. $U_{TC} : 3,200Vac/10s$							
Nominal Capacitance C_N [μF]	Dimensions		Maximum ripple current (Arms) I_{max}^* [Arms / at50°C, 1k ~ 10kHz]	Maximum peak current \hat{i} [kA]	Maximum Surge current I_s [kA]	Equivalent Series Resistance ESR [m Ω]	Equivalent Series Inductance ESL [nH]	Thermal resistance R_{th} [K/W]	Part number
	Diameter ϕD [mm]	Length of the case L_1 [mm]							
100	85	70	25	3	9	3.8	60	8.1	MLC1300V107KB8570
110	85	75	25	3	9	4.1	65	7.6	MLC1300V117KB8575
	88.5	70	26	3	9	3.5	60	8.2	MLC1300V117KB88570
120	88.5	75	26	3	9	3.8	65	7.6	MLC1300V127KB88575
130	85	80	25	3	9	4.2	65	7.3	MLC1300V137KB8580
140	85	87	24	3	9	4.8	75	7.0	MLC1300V147KB8587
	88.5	80	26	3	9	4.0	65	7.2	MLC1300V147KB88580
150	100	70	32	4	12	2.7	60	6.9	MLC1300V157KB10070
160	85	95	24	3	9	5.4	80	6.3	MLC1300V167KB8595
	88.5	87	26	3	9	4.3	75	6.7	MLC1300V167KB88587
170	100	75	32	4	12	2.9	65	6.5	MLC1300V177KB10075
180	88.5	95	26	3	9	4.8	80	6.0	MLC1300V187KB88595
	100	80	31	4	12	3.3	65	6.2	MLC1300V187KB10080
190	85	106	24	3	9	6.0	90	5.6	MLC1300V197KB85106
200	88.5	106	25	3	9	5.7	90	5.5	MLC1300V207KB885106
210	85	125	47	6	18	1.9	40	4.7	MLC1300V217KB85125
	100	87	31	4	12	3.5	75	5.8	MLC1300V217KB10087
	116	70	39	6	18	2.1	60	5.9	MLC1300V217KB11670
220	85	120	23	3	9	7.0	100	5.2	MLC1300V227KB85120
230	85	135	47	6	18	2.0	40	4.3	MLC1300V237KB85135
	88.5	125	50	7	21	1.7	40	4.6	MLC1300V237KB885125
	116	75	39	6	18	2.3	65	5.5	MLC1300V237KB11675
240	88.5	120	25	3	9	6.5	100	4.8	MLC1300V247KB885120
	100	95	31	4	12	3.8	80	5.2	MLC1300V247KB10095
250	88.5	135	49	7	21	1.9	40	4.3	MLC1300V257KB885135
260	85	145	47	6	18	2.2	45	4.0	MLC1300V267KB85145
	116	80	39	6	18	2.5	65	5.2	MLC1300V267KB11680
270	100	106	30	4	12	4.4	90	4.8	MLC1300V277KB100106
280	88.5	145	49	7	21	2.0	45	4.1	MLC1300V287KB885145
290	85	159	46	6	18	2.4	50	3.8	MLC1300V297KB85159
	116	87	38	6	18	2.7	75	4.9	MLC1300V297KB11687
300	100	125	59	9	27	1.4	40	3.9	MLC1300V307KB100125
310	140	70	42	9	27	1.7	60	6.5	MLC1300V317KB14070
320	88.5	159	49	7	21	2.2	50	3.7	MLC1300V327KB885159
	100	120	30	4	12	5.1	100	4.2	MLC1300V327KB100120
	85	175	46	6	18	2.7	55	3.4	MLC1300V337KB85175
330	100	135	59	9	27	1.5	40	3.6	MLC1300V337KB100135
	116	95	38	6	18	3.0	80	4.5	MLC1300V337KB11695
	140	75	43	9	27	1.7	65	6.2	MLC1300V357KB14075
350	140	75	43	9	27	1.7	65	6.2	MLC1300V357KB14075
360	88.5	175	49	7	21	2.5	55	3.3	MLC1300V367KB885175
370	100	145	59	9	27	1.7	45	3.3	MLC1300V377KB100145
380	85	197	46	6	18	3.1	60	3.0	MLC1300V387KB85197
	116	106	38	6	18	3.4	90	3.9	MLC1300V387KB116106
	140	80	42	9	27	1.9	65	5.8	MLC1300V387KB14080
410	88.5	197	48	7	21	2.9	60	2.9	MLC1300V417KB885197
420	100	159	59	9	27	1.8	50	3.1	MLC1300V427KB100159
430	116	125	70	12	36	1.1	40	3.5	MLC1300V427KB116125
	140	87	42	9	27	2.1	75	5.3	MLC1300V437KB14087
450	85	225	45	6	18	3.5	70	2.7	MLC1300V457KB85225
	116	120	37	6	18	3.9	100	3.6	MLC1300V457KB116120
460	116	135	70	12	36	1.2	40	3.3	MLC1300V467KB116135
470	100	175	57	9	27	2.0	55	2.9	MLC1300V477KB100175
480	88.5	225	47	7	21	3.3	70	2.7	MLC1300V487KB885225
490	140	95	41	9	27	2.3	80	5.1	MLC1300V497KB14095
520	116	145	70	12	36	1.3	45	3.0	MLC1300V527KB116145
550	100	197	57	9	27	2.3	60	2.6	MLC1300V557KB100197
	140	106	40	9	27	2.6	90	4.7	MLC1300V557KB140106
580	116	159	70	12	36	1.4	50	2.8	MLC1300V587KB116159
630	140	125	75	18	54	0.9	40	3.9	MLC1300V637KB140125
650	100	225	57	9	27	2.6	70	2.3	MLC1300V657KB100225
	140	120	40	9	27	3.0	100	4.1	MLC1300V657KB140120
660	116	175	69	12	36	1.6	55	2.6	MLC1300V667KB116175
700	140	135	75	18	54	0.9	40	3.9	MLC1300V707KB140135
760	116	197	69	12	36	1.8	60	2.3	MLC1300V767KB116197
770	140	145	74	18	54	1.0	45	3.6	MLC1300V777KB140145
870	140	159	74	18	54	1.1	50	3.3	MLC1300V877KB140159
900	116	225	69	13	39	2.1	70	2.0	MLC1300V907KB116225
990	140	175	74	18	54	1.2	55	3.0	MLC1300V997KB140175
1,100	140	197	73	18	54	1.4	60	2.6	MLC1300V118KB140197
1,300	140	225	72	18	54	1.6	70	2.4	MLC1300V138KB140225

PLASTIC FILM CAPACITORS

* • Please inquire us in case low frequency (commercial frequency) or frequency above 10kHz is included in ripple current.
 • Maximum permissible ripple current is calculated by the value in this table with frequency and temperature correction factors.
 Also the maximum current must be controlled below the permissible terminal current .
 Please refer useful life graph based on ambient temperature and voltage.

$$\theta_{HOTSPOT} = T_a + I^2 \times ESR \times R_{th}$$

POWER ELECTRONICS USE PLASTIC FILM CAPACITORS

Standard Products Table

Rated d.c voltage $U_N : 1,500Vdc$		Max.ripple voltage $U_r : 350V$ Non repetitive surge voltage $U_s : 2,250V$ Voltage test between terminals $U_{TT} : 2,250Vdc/10s$ Voltage test terminals to case. $U_{Tc} : 3,200Vac/10s$							
Nominal Capacitance C_N [μF]	Dimensions		Maximum ripple current (Arms) I_{max}^* [Arms / at50°C, 1k ~ 10kHz]	Maximum peak current \hat{i} [kA]	Maximum Surge current I_s [kA]	Equivalent Series Resistance ESR [m Ω]	Equivalent Series Inductance ESL [nH]	Thermal resistance R_{th} [K/W]	Part number
	Diameter ϕD [mm]	Length of the case L_1 [mm]							
70	85	70	23	2	6	4.6	60	8.0	MLC1500V706KB8570
80	85	75	23	2	6	4.8	65	7.7	MLC1500V806KB8575
	88.5	70	25	3	9	4.0	60	7.8	MLC1500V806KB88570
90	85	80	23	3	9	5.1	65	7.1	MLC1500V906KB8580
	88.5	75	25	3	9	4.3	65	7.2	MLC1500V906KB88575
100	85	87	22	2	6	5.7	75	7.0	MLC1500V107KB8587
	88.5	80	24	3	9	4.7	65	7.2	MLC1500V107KB88580
110	85	95	22	2	6	6.5	80	6.1	MLC1500V117KB8595
	88.5	87	24	3	9	5.2	75	6.5	MLC1500V117KB88587
120	100	70	30	4	12	3.1	60	6.9	MLC1500V117KB10070
	100	75	30	4	12	3.4	65	6.3	MLC1500V127KB10075
130	85	106	22	3	9	7.3	90	5.5	MLC1500V137KB85106
	88.5	95	24	3	9	5.6	80	6.0	MLC1500V137KB88595
	100	80	29	4	12	3.8	65	6.1	MLC1500V137KB10080
150	88.5	106	24	3	9	6.4	90	5.3	MLC1500V157KB885106
	100	87	29	4	12	4.0	75	5.7	MLC1500V157KB10087
	116	70	37	5	15	2.5	60	5.7	MLC1500V157KB11670
160	85	120	22	3	9	8.1	100	4.9	MLC1500V167KB85120
	116	75	36	5	15	2.7	65	5.5	MLC1500V167KB11675
170	88.5	120	23	3	9	7.7	100	4.8	MLC1500V177KB885120
	100	95	29	4	12	4.5	80	5.1	MLC1500V177KB10095
180	116	80	36	5	15	2.9	65	5.1	MLC1500V187KB11680
190	100	106	28	4	12	5.2	90	4.7	MLC1500V197KB100106
200	85	159	42	5	15	2.9	50	3.8	MLC1500V207KB85159
	116	87	34	5	15	3.2	75	5.2	MLC1500V207KB11687
230	85	175	42	5	15	3.2	55	3.4	MLC1500V237KB85175
	88.5	159	46	6	18	2.6	50	3.6	MLC1500V237KB885159
	100	120	28	4	12	5.9	100	4.2	MLC1500V237KB100120
	116	95	34	5	15	3.5	80	4.7	MLC1500V237KB11695
250	140	70	40	8	24	1.8	60	6.8	MLC1500V237KB14070
	140	75	40	8	24	2.0	65	6.2	MLC1500V257KB14075
260	88.5	175	45	6	18	2.9	55	3.3	MLC1500V267KB885175
270	85	197	42	5	15	3.6	60	3.0	MLC1500V277KB85197
	116	106	34	5	15	3.9	90	4.3	MLC1500V277KB116106
280	140	80	40	8	24	2.1	65	5.8	MLC1500V287KB14080
300	88.5	197	45	6	18	3.3	60	2.9	MLC1500V307KB885197
	100	159	54	7	21	2.1	50	3.2	MLC1500V307KB100159
320	85	225	42	5	15	4.2	70	2.6	MLC1500V327KB85225
	116	120	34	5	15	4.5	100	3.7	MLC1500V327KB116120
	140	87	40	8	24	2.3	75	5.3	MLC1500V327KB14087
340	100	175	53	7	21	2.3	55	3.0	MLC1500V347KB100175
350	88.5	225	44	6	18	3.8	70	2.7	MLC1500V357KB885225
360	140	95	39	8	24	2.5	80	5.1	MLC1500V367KB14095
390	100	197	53	8	24	2.7	60	2.6	MLC1500V397KB100197
400	140	106	38	8	24	2.9	90	4.7	MLC1500V407KB140106
410	116	159	65	10	30	1.7	50	2.8	MLC1500V417KB116159
460	100	225	52	8	24	3.1	70	2.3	MLC1500V467KB100225
470	116	175	65	10	30	1.8	55	2.5	MLC1500V477KB116175
480	140	120	38	8	24	3.3	100	4.1	MLC1500V487KB140120
540	116	197	64	10	30	2.1	60	2.3	MLC1500V547KB116197
640	116	225	64	10	30	2.4	70	2.0	MLC1500V647KB116225
	140	159	71	16	48	1.2	50	3.2	MLC1500V647KB140159
720	140	175	70	16	48	1.3	55	3.1	MLC1500V727KB140175
810	140	197	69	16	48	1.5	60	2.8	MLC1500V817KB140197
960	140	225	69	16	48	1.8	70	2.3	MLC1500V967KB140225

- * • Please inquire us in case low frequency (commercial frequency) or frequency above 10kHz is included in ripple current.
 • Maximum permissible ripple current is calculated by the value in this table with frequency and temperature correction factors.
 Also the maximum current must be controlled below the permissible terminal current .
 Please refer useful life graph based on ambient temperature and voltage.

$$\theta_{HOTSPOT} = T_a + I^2 \times ESR \times R_{th}$$

PLASTIC FILM CAPACITORS