

HU3 Series

Useful of 4,000 hours at 105°C

Standard



- Conform RoHS

Features

- The HU3 series is the standard products.

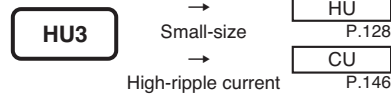

Product Specifications

Items	Specifications
Temperature range	-40°C ~ +105°C
Rated voltage	16 ~ 450V.DC
Capacitance tolerance	±20% (20°C, 120Hz)
Leakage current	0.02CV (µA) or 3mA, whichever is smaller or less (20°C, after 5 minutes) [C = nominal capacitance (µF), V = rated voltage (V)]
Dissipation factor	Less than the value specified in the standard products table. (20°C, 120Hz)
Permissible ripple current	As specified in the standard product table. (105°C, 120Hz)
Endurance	After the rated voltage with specified ripple current is applied at 105°C for 2,000 hours : Capacitance change : Within ±15% of the initial value measured Dissipation factor : 175% or less than the initial value specified Leakage current : Less than or equal to the initial value specified
Shelf life	The following specification shall be meet when the capacitor are restored to 20°C after storage of 500 hours at 105°C with no voltage applied. Before the measurement, the capacitor shall be preconditioned by applying the voltage treatment according to Item 4.1 of JIS C 5101-4. Capacitance change : Within ±15% of the initial value measured Dissipation factor : 175% or less than the initial value specified Leakage current : Less than or equal to the initial value specified
Others	JIS C 5101-4

Dimensions

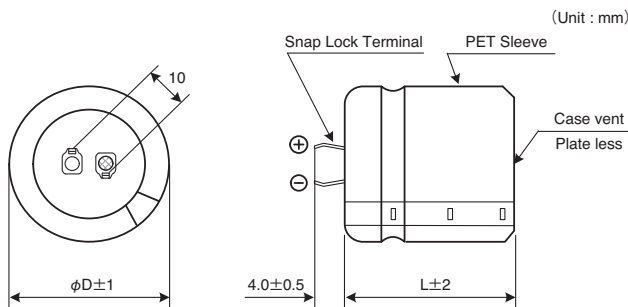

Ripple current correction coefficient

Temperature (°C)	60	70	85	105		
Correction coefficient	2.2	2.0	1.8	1.0		
Frequency (Hz)	50/60	120	300	1K	≥10K	
Correction coefficient	16~100V.DC	0.7	1.0	1.1	1.2	1.2
	160~450V.DC	0.7	1.0	1.1	1.3	1.4

Terminal permissible current is limited to 10Arms. (Even if calculated the permissible ripple current with the correction coefficient exceeds 10Arms)
Please consult us when the ripple voltage exceeds 70Vp-p.

Product code

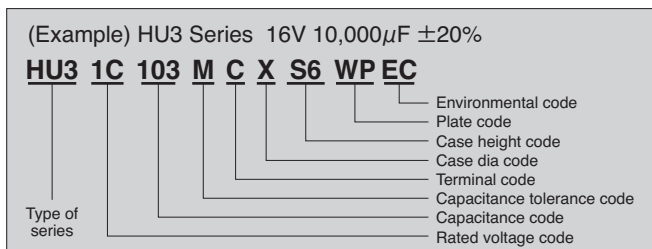

Refer to page 118-119 for other terminal shape available on request.

SNAP MOUNT TYPE ALUMINUM ELECTROLYTIC CAPACITORS

HU3 Series

Standard Products Table

Rated Voltage (V. DC)	Capacitance (μF)	Case size φD×L (mm)	tanδ 20°C, 120Hz	Ripple current (Arms) 105°C, 120Hz	ESR (typ.) (mΩ) 20°C, 100Hz	Product name
16	4,700	22×25	0.50	0.93	67	HU31C472MCXS2WPEC
	6,800	22×35	0.50	1.27	46	HU31C682MCXS4WPEC
		25×30	0.50	1.26	46	HU31C682MCYS3WPEC
	10,000	22×45	0.50	1.43	38	HU31C103MCXS6WPEC
		25×35	0.50	1.36	38	HU31C103MCYS4WPEC
		30×25	0.50	1.30	38	HU31C103MCZS2WPEC
	15,000	25×45	0.50	1.84	25	HU31C153MCYS6WPEC
		30×35	0.50	1.77	25	HU31C153MCZS4WPEC
		35×30	0.50	1.78	25	HU31C153MCAS3WPEC
	22,000	30×45	0.50	2.36	20	HU31C223MCZS6WPEC
35×35		0.50	2.27	20	HU31C223MCAS4WPEC	
33,000	35×50	0.50	2.95	15	HU31C333MCAS7WPEC	
25	3,300	22×25	0.40	0.87	116	HU31E332MCXS2WPEC
	4,700	22×30	0.40	1.00	81	HU31E472MCXS3WPEC
		25×25	0.40	0.98	81	HU31E472MCYS2WPEC
	6,800	22×35	0.40	1.27	65	HU31E682MCXS4WPEC
		25×30	0.40	1.27	65	HU31E682MCYS3WPEC
	10,000	30×25	0.40	1.27	65	HU31E682MCZS2WPEC
		22×45	0.40	1.43	45	HU31E103MCXS6WPEC
		25×35	0.40	1.38	45	HU31E103MCYS4WPEC
		30×30	0.40	1.38	45	HU31E103MCZS3WPEC
	15,000	35×25	0.40	1.38	45	HU31E103MCAS2WPEC
		25×45	0.40	1.84	30	HU31E153MCYS6WPEC
		30×35	0.40	1.78	30	HU31E153MCZS4WPEC
	22,000	35×30	0.40	1.78	30	HU31E153MCAS3WPEC
		30×45	0.40	2.36	20	HU31E223MCZS6WPEC
	33,000	35×40	0.40	2.38	20	HU31E223MCAS5WPEC
		35×50	0.40	2.95	15	HU31E333MCAS7WPEC
35	2,200	22×25	0.35	0.71	108	HU31V222MCXS2WPEC
	3,300	22×30	0.35	0.93	72	HU31V332MCXS3WPEC
		25×25	0.35	0.92	72	HU31V332MCYS2WPEC
	4,700	22×35	0.35	1.05	61	HU31V472MCXS4WPEC
		25×30	0.35	1.05	61	HU31V472MCYS3WPEC
		30×25	0.35	1.05	61	HU31V472MCZS2WPEC
	6,800	22×50	0.35	1.46	55	HU31V682MCXS7WPEC
		25×40	0.35	1.40	55	HU31V682MCYS5WPEC
		30×30	0.35	1.34	55	HU31V682MCZS3WPEC
		35×25	0.35	1.34	55	HU31V682MCAS2WPEC
	10,000	25×50	0.35	1.57	35	HU31V103MCYS7WPEC
		30×35	0.35	1.46	35	HU31V103MCZS4WPEC
		35×30	0.35	1.46	35	HU31V103MCAS3WPEC
	15,000	30×50	0.35	2.03	25	HU31V153MCZS7WPEC
		35×40	0.35	1.96	25	HU31V153MCAS5WPEC
	50	1,500	22×25	0.30	0.68	159
2,200		22×30	0.30	0.76	108	HU31H222MCXS3WPEC
		25×25	0.30	0.75	108	HU31H222MCYS2WPEC
3,300		22×35	0.30	0.99	72	HU31H332MCXS4WPEC
		25×30	0.30	0.98	72	HU31H332MCYS3WPEC
		30×25	0.30	0.99	72	HU31H332MCZS2WPEC
4,700		22×45	0.30	1.16	50	HU31H472MCXS6WPEC
		25×35	0.30	1.11	50	HU31H472MCYS4WPEC
		30×30	0.30	1.12	50	HU31H472MCZS3WPEC
		35×25	0.30	1.12	50	HU31H472MCAS2WPEC
6,800		25×50	0.30	1.53	35	HU31H682MCYS7WPEC
		30×35	0.30	1.42	35	HU31H682MCZS4WPEC
		35×30	0.30	1.42	35	HU31H682MCAS3WPEC
10,000		30×45	0.35	1.59	31	HU31H103MCZS6WPEC
		35×40	0.35	1.60	31	HU31H103MCAS5WPEC
15,000		35×50	0.35	2.13	25	HU31H153MCAS7WPEC

Rated Voltage (V. DC)	Capacitance (μF)	Case size φD×L (mm)	tanδ 20°C, 120Hz	Ripple current (Arms) 105°C, 120Hz	ESR (typ.) (mΩ) 20°C, 100Hz	Product name
63	1,000	22×25	0.25	0.56	238	HU31J102MCXS2WPEC
	1,500	22×30	0.25	0.73	159	HU31J152MCXS3WPEC
		25×25	0.25	0.72	159	HU31J152MCYS2WPEC
	2,200	22×35	0.25	0.81	108	HU31J222MCXS4WPEC
		25×30	0.25	0.80	108	HU31J222MCYS3WPEC
		30×25	0.25	0.81	108	HU31J222MCZS2WPEC
	3,300	22×45	0.25	1.09	80	HU31J332MCXS6WPEC
		25×40	0.25	1.09	80	HU31J332MCYS5WPEC
		30×30	0.25	1.05	80	HU31J332MCZS3WPEC
		35×25	0.25	1.05	80	HU31J332MCAS2WPEC
4,700	25×50	0.25	1.27	60	HU31J472MCYS7WPEC	
	30×35	0.25	1.18	60	HU31J472MCZS4WPEC	
6,800	35×30	0.25	1.18	60	HU31J472MCAS3WPEC	
	30×45	0.25	1.55	40	HU31J682MCZS6WPEC	
10,000	35×40	0.25	1.56	40	HU31J682MCAS5WPEC	
80	1,000	22×30	0.20	0.59	230	HU31K102MCXS3WPEC
		25×25	0.20	0.59	230	HU31K102MCYS2WPEC
	1,500	22×35	0.20	0.77	155	HU31K152MCXS4WPEC
		25×30	0.20	0.77	155	HU31K152MCYS3WPEC
		30×25	0.20	0.77	155	HU31K152MCZS2WPEC
	2,200	22×50	0.20	0.93	105	HU31K222MCXS7WPEC
		25×40	0.20	0.89	105	HU31K222MCYS5WPEC
		30×30	0.20	0.85	105	HU31K222MCZS3WPEC
		35×25	0.20	0.85	105	HU31K222MCAS2WPEC
	3,300	25×50	0.20	1.19	70	HU31K332MCYS7WPEC
		30×40	0.20	1.16	70	HU31K332MCZS5WPEC
		35×30	0.20	1.11	70	HU31K332MCAS3WPEC
	4,700	30×50	0.25	1.34	50	HU31K472MCZS7WPEC
		35×40	0.25	1.30	50	HU31K472MCAS5WPEC
	6,800	35×50	0.25	1.69	35	HU31K682MCAS7WPEC
	100	1,000	22×30	0.20	0.59	180
25×25			0.20	0.59	180	HU32A102MCYS2WPEC
1,500		22×40	0.20	0.81	120	HU32A152MCXS5WPEC
		25×35	0.20	0.81	120	HU32A152MCYS4WPEC
		30×25	0.20	0.77	120	HU32A152MCZS2WPEC
2,200		25×45	0.20	0.93	82	HU32A222MCYS6WPEC
		30×35	0.20	0.90	82	HU32A222MCZS4WPEC
3,300		30×45	0.20	1.21	60	HU32A332MCZS6WPEC
		35×35	0.20	1.16	60	HU32A332MCAS4WPEC
4,700		35×45	0.25	1.35	45	HU32A472MCAS6WPEC
160	330	22×25	0.15	0.98	430	HU32C331MCXS2WPEC
	390	22×30	0.15	1.10	365	HU32C391MCXS3WPEC
		25×25	0.15	1.09	365	HU32C391MCYS2WPEC
	470	22×30	0.15	1.21	305	HU32C471MCXS3WPEC
		25×25	0.15	1.19	305	HU32C471MCYS2WPEC
		22×35	0.15	1.40	255	HU32C561MCXS4WPEC
	560	25×30	0.15	1.40	255	HU32C561MCYS3WPEC
		30×25	0.15	1.40	255	HU32C561MCZS2WPEC
	680	22×40	0.15	1.62	210	HU32C681MCXS5WPEC
		25×35	0.15	1.61	210	HU32C681MCYS4WPEC
		30×25	0.15	1.54	210	HU32C681MCZS2WPEC
	820	22×45	0.15	1.86	175	HU32C821MCXS6WPEC
		25×40	0.15	1.86	175	HU32C821MCYS5WPEC
		30×30	0.15	1.79	175	HU32C821MCZS3WPEC
		35×25	0.15	1.79	175	HU32C821MCAS2WPEC
	1,000	25×45	0.15	2.15	145	HU32C102MCYS6WPEC
30×35		0.15	2.09	145	HU32C102MCZS4WPEC	
1,200	35×25	0.15	1.98	145	HU32C102MCAS2WPEC	
	25×50	0.15	2.46	120	HU32C122MCYS7WPEC	
	30×35	0.15	2.29	120	HU32C122MCZS4WPEC	
1,500	35×30	0.15	2.29	120	HU32C122MCAS3WPEC	
	30×45	0.15	2.80	95	HU32C152MCZS6WPEC	
1,800	35×35	0.15	2.72	95	HU32C152MCAS4WPEC	
	35×40	0.15	3.09	80	HU32C182MCAS5WPEC	

ALUMINUM ELECTROLYTIC CAPACITORS

SNAP MOUNT TYPE ALUMINUM ELECTROLYTIC CAPACITORS

Standard Products Table

Rated Voltage (V. DC)	Capacitance (μF)	Case size φD×L (mm)	tanδ 20°C, 120Hz	Ripple current (Arms) 105°C, 120Hz	ESR(typ.) (mΩ) 20°C, 100Hz	Product name
180	330	22×25	0.15	0.94	375	HU32P331MCXS2WPEC
		25×25	0.15	1.00	375	HU32P331MCYS2WPEC
	390	22×30	0.15	1.10	320	HU32P391MCXS3WPEC
		25×25	0.15	1.09	320	HU32P391MCYS2WPEC
	470	22×30	0.15	1.20	265	HU32P471MCXS3WPEC
		25×25	0.15	1.19	265	HU32P471MCYS2WPEC
		30×25	0.15	1.28	265	HU32P471MCZS2WPEC
	560	22×35	0.15	1.39	225	HU32P561MCXS4WPEC
		25×30	0.15	1.40	225	HU32P561MCYS3WPEC
		30×25	0.15	1.40	225	HU32P561MCZS2WPEC
	680	22×40	0.15	1.61	185	HU32P681MCXS5WPEC
		25×35	0.15	1.63	185	HU32P681MCYS4WPEC
		30×25	0.15	1.54	185	HU32P681MCZS2WPEC
	820	35×25	0.15	1.63	185	HU32P681MCAS2WPEC
		22×45	0.15	1.86	155	HU32P821MCXS6WPEC
		25×40	0.15	1.87	155	HU32P821MCYS5WPEC
	1,000	30×30	0.15	1.79	155	HU32P821MCZS3WPEC
		35×25	0.15	1.79	155	HU32P821MCAS2WPEC
		25×45	0.15	2.15	125	HU32P102MCYS6WPEC
	1,200	30×35	0.15	2.09	125	HU32P102MCZS4WPEC
35×30		0.15	2.09	125	HU32P102MCAS3WPEC	
30×40		0.15	2.39	105	HU32P122MCZS5WPEC	
1,500	35×30	0.15	2.29	105	HU32P122MCAS3WPEC	
	30×45	0.15	2.79	85	HU32P152MCZS6WPEC	
1,800	35×35	0.15	2.72	85	HU32P152MCAS4WPEC	
	35×40	0.15	3.09	70	HU32P182MCAS5WPEC	
350	120	22×25	0.15	0.57	770	HU32V121MCXS2WPEC
		25×25	0.15	0.60	770	HU32V121MCYS2WPEC
	150	22×30	0.15	0.68	615	HU32V151MCXS3WPEC
		25×25	0.15	0.67	615	HU32V151MCYS2WPEC
		30×25	0.15	0.72	615	HU32V151MCZS2WPEC
	180	22×35	0.15	0.79	520	HU32V181MCXS4WPEC
		25×30	0.15	0.79	520	HU32V181MCYS3WPEC
		30×25	0.15	0.79	520	HU32V181MCZS2WPEC
	220	22×45	0.15	0.96	450	HU32V221MCXS6WPEC
		25×35	0.15	0.92	450	HU32V221MCYS4WPEC
		30×25	0.15	0.87	450	HU32V221MCZS2WPEC
	270	35×25	0.15	0.93	450	HU32V221MCAS2WPEC
		25×40	0.15	1.07	366	HU32V271MCYS5WPEC
		30×30	0.15	1.03	366	HU32V271MCZS3WPEC
	330	35×25	0.15	1.02	366	HU32V271MCAS2WPEC
		25×45	0.15	1.24	299	HU32V331MCYS6WPEC
		30×35	0.15	1.20	299	HU32V331MCZS4WPEC
	390	35×25	0.15	1.13	299	HU32V331MCAS2WPEC
		30×40	0.15	1.36	253	HU32V391MCZS5WPEC
		35×30	0.15	1.30	253	HU32V391MCAS3WPEC
470	35×35	0.15	1.50	210	HU32V471MCAS4WPEC	
	560	35×40	0.15	1.72	181	HU32V561MCAS5WPEC

Rated Voltage (V. DC)	Capacitance (μF)	Case size φD×L (mm)	tanδ 20°C, 120Hz	Ripple current (Arms) 105°C, 120Hz	ESR(typ.) (mΩ) 20°C, 100Hz	Product name
400	100	22×25	0.15	0.57	924	HU32G101MCXS2WPEC
		22×30	0.15	0.67	770	HU32G121MCXS3WPEC
	120	25×25	0.15	0.66	770	HU32G121MCYS2WPEC
		22×35	0.15	0.79	615	HU32G151MCXS4WPEC
	150	25×30	0.15	0.79	615	HU32G151MCYS3WPEC
		30×25	0.15	0.79	615	HU32G151MCZS2WPEC
		22×40	0.15	0.91	520	HU32G181MCXS5WPEC
	180	25×35	0.15	0.91	520	HU32G181MCYS4WPEC
		30×25	0.15	0.87	520	HU32G181MCZS2WPEC
		25×40	0.15	1.06	450	HU32G221MCYS5WPEC
	220	30×30	0.15	1.02	450	HU32G221MCZS3WPEC
		35×25	0.15	1.02	450	HU32G221MCAS2WPEC
		25×45	0.15	1.23	366	HU32G271MCXS6WPEC
	270	30×35	0.15	1.19	366	HU32G271MCZS4WPEC
		35×25	0.15	1.13	366	HU32G271MCAS2WPEC
		30×40	0.15	1.38	299	HU32G331MCZS5WPEC
	330	35×30	0.15	1.32	299	HU32G331MCAS3WPEC
		390	35×35	0.15	1.51	253
	470	35×45	0.15	1.80	210	HU32G471MCAS6WPEC
		560	35×45	0.15	1.97	181
420	82	22×25	0.15	0.52	1,242	HU3420V820MCXS2WPEC
		25×25	0.15	0.54	1,242	HU3420V820MCYS2WPEC
	100	22×30	0.15	0.61	1,019	HU3420V101MCXS3WPEC
		25×25	0.15	0.61	1,019	HU3420V101MCYS2WPEC
	120	22×35	0.15	0.71	850	HU3420V121MCXS4WPEC
		25×25	0.15	0.66	850	HU3420V121MCYS2WPEC
		30×25	0.15	0.70	850	HU3420V121MCZS2WPEC
	150	22×40	0.15	0.83	679	HU3420V151MCXS5WPEC
		25×30	0.15	0.79	679	HU3420V151MCYS3WPEC
		30×25	0.15	0.79	679	HU3420V151MCZS2WPEC
	180	25×35	0.15	0.91	566	HU3420V181MCXS4WPEC
		30×25	0.15	0.87	566	HU3420V181MCZS2WPEC
		35×25	0.15	0.90	566	HU3420V181MCAS2WPEC
	220	25×45	0.15	1.11	463	HU3420V221MCYS6WPEC
		30×30	0.15	1.02	463	HU3420V221MCZS3WPEC
		35×25	0.15	1.02	463	HU3420V221MCAS2WPEC
	270	30×35	0.15	1.19	377	HU3420V271MCZS4WPEC
		35×30	0.15	1.19	377	HU3420V271MCAS3WPEC
		30×45	0.15	1.44	309	HU3420V331MCZS6WPEC
	330	35×35	0.15	1.39	309	HU3420V331MCAS4WPEC
390		35×40	0.15	1.58	261	HU3420V391MCAS5WPEC
470	35×45	0.15	1.80	218	HU3420V471MCAS6WPEC	
	68	22×25	0.15	0.47	1,499	HU32W680MCXS2WPEC
82		22×30	0.15	0.55	1,242	HU32W820MCXS3WPEC
	100	25×25	0.15	0.55	1,242	HU32W820MCYS2WPEC
120		22×35	0.15	0.65	1,019	HU32W101MCXS4WPEC
	150	25×30	0.15	0.64	1,019	HU32W101MCYS3WPEC
180		22×40	0.15	0.75	850	HU32W121MCXS5WPEC
	25×30	0.15	0.71	850	HU32W121MCYS3WPEC	
	30×25	0.15	0.71	850	HU32W121MCZS2WPEC	
220	25×40	0.15	0.88	679	HU32W151MCYS5WPEC	
	30×30	0.15	0.84	679	HU32W151MCZS3WPEC	
	35×25	0.15	0.84	679	HU32W151MCAS2WPEC	
270	25×45	0.15	1.01	566	HU32W181MCYS6WPEC	
	30×30	0.15	0.92	566	HU32W181MCZS3WPEC	
	35×25	0.15	0.92	566	HU32W181MCAS2WPEC	
330	30×35	0.15	1.07	463	HU32W221MCZS4WPEC	
	35×30	0.15	1.08	463	HU32W221MCAS3WPEC	
	30×45	0.15	1.30	377	HU32W271MCZS6WPEC	
390	35×35	0.15	1.25	377	HU32W271MCAS4WPEC	
	330	35×40	0.15	1.45	309	HU32W331MCAS5WPEC
450	390	35×45	0.15	1.64	261	HU32W391MCAS6WPEC

ALUMINUM ELECTROLYTIC CAPACITORS

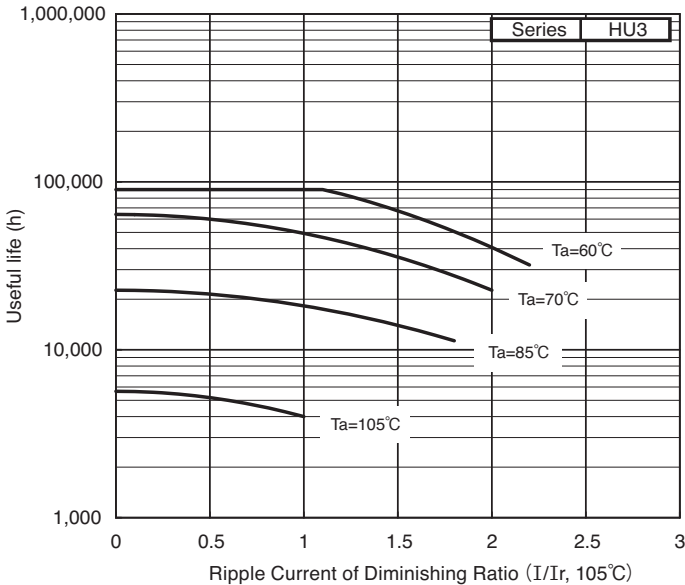

Life time graph

Useful life depending on ambient temperature Ta and ripple current operating conditions I versus rated ripple current at 105°C, 120Hz