

FXR3 Series Useful of 8,000 hours at 85°C

- Conform RoHS

Features

- FXR3 series has smaller case size (ave.10%) and higher ripple current (ave.20%) compared with FX2 series. These features are accomplished by new heat radiation structure and low ESR material.

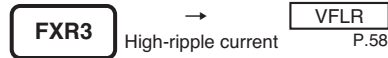

Product Specifications

Items	Specifications
Temperature range	-40°C ~ +85°C
Rated voltage	400 ~ 500V.DC
Capacitance tolerance	±20% (20°C, 120Hz)
Leakage current	0.01CV (µA) or 5mA, whichever is smaller or less (20°C, after 5 minutes) [C = nominal capacitance (µA), V = rated voltage (V)]
Dissipation factor	Less than the value specified in the standard products table. (20°C, 120Hz)
Permissible ripple current	As specified in the standard products table. (85°C, 120Hz)
Endurance	After the rated voltage with specified ripple current is applied at 85°C for 5,000 hours : Capacitance change : Within ±15% of the initial value measured Dissipation factor : 175% or less than the initial value specified Leakage current : Less than or equal to the initial value specified
Shelf life	The following specification shall be meet when the capacitor are restored to 20°C after storage of 500 hours at 85°C with no voltage applied. Before the measurement, the capacitor shall be preconditioned by applying the voltage treatment according to Item 4.1 of JIS C 5101-4. Capacitance change : Within ±15% of the initial value measured Dissipation factor : 175% or less than the initial value specified Leakage current : Less than or equal to the initial value specified
Others	JIS C 5101-4

Dimensions

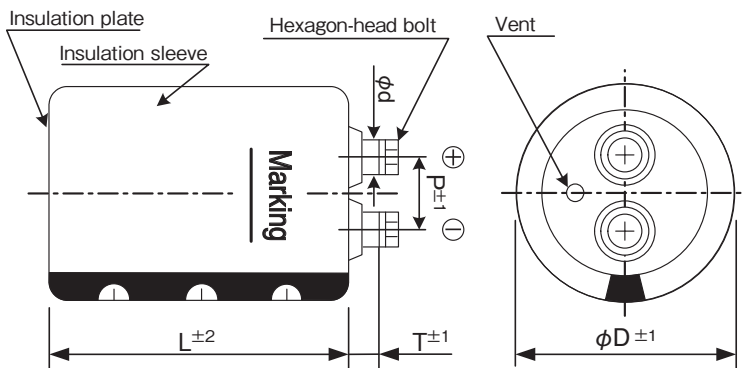

(unit : mm)

φD	P	T	φd	Hexagon-head bolt	Cap material
64	28.6	8.0	11.0	M5×10	Phenol resin
77	31.5	9.0	12.0	M6×12	Phenol resin
90	31.5	8.0	12.0	M6×12	Phenol resin

Ripple current correction coefficient

Temperature (°C)	40	60	85		
Correction coefficient	1.89	1.67	1.00		
Frequency (Hz)	50/60	120	300	1K	≥10K
Correction coefficient	0.7	1.0	1.1	1.3	1.4
Forced wind (m/s)	<0.5	0.5≤			
Correction coefficient	1.0	1.1			

Terminal permissible currents: 60Arms for M5 ; 100Arms for M6.
Please use this type of capacitor at a terminal current below the permissible.

Product code

(Example) FXR3 Series 400V 12,000 µF ±20%

FXR3 2G 123 Y F 150 PH

- Type of series
- Sealing code
- Case height code
- Case dia code
- Type of bracket code
- Capacitance code
- Rated voltage code

Refer to page 21 for product code.

Bracket

- Refer to page 22-23 for shapes and dimensions.
- Product names in the Standard Products Table correspond to the bracket for Type Y, but Type I bracket may be used (Type of bracket code = I).
- If bracket are not necessary, enter "N" for the type of bracket code.
- Bracket will be delivered separately.

SCREW TERMINAL TYPE ALUMINUM ELECTROLYTIC CAPACITORS

FXR3 Series

Standard Products Table

Rated Voltage (V. DC)	Capacitance (μF)	Case size φD×L(mm)	tanδ 20°C, 120Hz	Ripple current (Arms) 85°C, 120Hz	ESR(typ.) (mΩ) 20°C, 100Hz	Z max (mΩ) 20°C, 10kHz	ESL(typ.) (nH)	Product name
400	3,900	64×94	0.20	15.6	26	28	22	FXR32G392YD094PH
	4,700	64×107	0.20	17.2	21	22	22	FXR32G472YD107PH
	5,600	64×147	0.20	20.6	18	19	22	FXR32G562YD147PH
		77×95	0.20	19.9	18	19	23	FXR32G562YE095PH
	6,800	64×164	0.20	23.8	15	16	22	FXR32G682YD164PH
		77×108	0.20	22.0	15	16	23	FXR32G682YE108PH
	8,200	64×187	0.20	26.7	12	12	22	FXR32G822YD187PH
		77×148	0.20	26.3	12	12	23	FXR32G822YE148PH
		90×97	0.20	25.9	12	12	23	FXR32G822YF097PH
	10,000	77×165	0.20	30.3	10	10	23	FXR32G103YE165PH
		90×126	0.20	30.1	10	10	23	FXR32G103YF126PH
	12,000	77×188	0.20	34.1	8	10	23	FXR32G123YE188PH
		90×150	0.20	34.0	8	10	23	FXR32G123YF150PH
	15,000	77×228	0.20	41.4	8	10	23	FXR32G153YE228PH
90×167		0.20	39.6	8	10	23	FXR32G153YF167PH	
18,000	90×190	0.20	44.4	6	9	23	FXR32G183YF190PH	
22,000	90×230	0.20	53.7	6	8	23	FXR32G223YF230PH	
450	2,700	64×94	0.20	12.7	38	40	22	FXR32W272YD094PH
	3,300	64×107	0.20	14.2	31	33	22	FXR32W332YD107PH
	3,900	64×123	0.20	16.2	26	28	22	FXR32W392YD123PH
		77×95	0.20	16.3	26	28	23	FXR32W392YE095PH
	4,700	64×147	0.20	18.5	21	22	22	FXR32W472YD147PH
		77×108	0.20	17.9	21	22	23	FXR32W472YE108PH
	5,600	64×164	0.20	21.1	18	19	22	FXR32W562YD164PH
		77×124	0.20	20.6	18	19	23	FXR32W562YE124PH
		90×97	0.20	21.0	18	19	23	FXR32W562YF097PH
	6,800	64×187	0.20	23.9	15	16	22	FXR32W682YD187PH
		77×148	0.20	23.5	15	16	23	FXR32W682YE148PH
		90×110	0.20	23.2	15	16	23	FXR32W682YF110PH
	8,200	77×165	0.20	27.0	12	12	23	FXR32W822YE165PH
		90×126	0.20	26.8	12	12	23	FXR32W822YF126PH
	10,000	77×188	0.20	30.6	10	10	23	FXR32W103YE188PH
		90×150	0.20	30.5	10	10	23	FXR32W103YF150PH
	12,000	77×228	0.20	36.2	8	10	23	FXR32W123YE228PH
		90×167	0.20	34.7	8	10	23	FXR32W123YF167PH
15,000	90×190	0.20	40.1	8	10	23	FXR32W153YF190PH	
18,000	90×230	0.20	47.1	6	9	23	FXR32W183YF230PH	
500	1,800	64×94	0.20	10.3	53	50	22	FXR32H182YD094PH
	2,200	64×107	0.20	11.4	40	35	22	FXR32H222YD107PH
	2,700	64×123	0.20	13.3	37	33	22	FXR32H272YD123PH
		77×95	0.20	13.4	37	33	24	FXR32H272YE095PH
	3,300	64×147	0.20	15.3	36	32	22	FXR32H332YD147PH
		77×108	0.20	14.8	36	32	24	FXR32H332YE108PH
	3,900	64×164	0.20	17.4	27	29	22	FXR32H392YD164PH
		77×124	0.20	17.0	27	29	24	FXR32H392YE124PH
		90×97	0.20	17.3	27	29	24	FXR32H392YF097PH
	4,700	64×187	0.20	19.7	25	25	22	FXR32H472YD187PH
		77×148	0.20	19.3	25	25	24	FXR32H472YE148PH
		90×110	0.20	19.1	25	25	24	FXR32H472YF110PH
	5,600	77×165	0.20	22.0	23	21	24	FXR32H562YE165PH
		90×126	0.20	21.9	23	21	24	FXR32H562YF126PH
	6,800	77×188	0.20	24.9	20	18	24	FXR32H682YE188PH
		90×150	0.20	24.8	20	18	24	FXR32H682YF150PH
	8,200	77×228	0.20	29.7	17	16	24	FXR32H822YE228PH
		90×167	0.20	28.4	17	16	24	FXR32H822YF167PH
10,000	90×190	0.20	32.0	15	14	24	FXR32H103YF190PH	
12,000	90×230	0.20	38.1	13	12	24	FXR32H123YF230PH	

ALUMINUM ELECTROLYTIC CAPACITORS

Life time graph

Useful life depending on ambient temperature T_a and ripple current operating conditions I versus rated ripple current at 85°C, 120Hz

ALUMINUM ELECTROLYTIC CAPACITORS

